

CENTRAL DISTRICT • OCKLAWAHA BASIN

Final TMDL Report

***Nutrient TMDLs for Lake Roberts
(WBID 2872A)***

***and Documentation in Support of Development of
Site-Specific Numeric Interpretations of
the Narrative Nutrient Criterion***

**Woo-Jun Kang
Water Quality Evaluation and TMDL Program
Division of Environmental Assessment and Restoration
Florida Department of Environmental Protection**

May 2017

**2600 Blair Stone Road
Mail Station 3575
Tallahassee, FL 32399-2400**



Acknowledgments

This analysis could not have been accomplished without the support of the Orange County Environmental Protection Division (EPD). Sincere thanks to the EPD for the tremendous support provided by Julie Bortles and Mitchell Katz. The Florida Department of Environmental Protection (DEP) would like to acknowledge Jeffrey Earhart of Cribb Philbeck Weaver Group (CPWG) and Susan Woodbery of TEAM Engineering, LLC for providing information from their projects. Additionally, significant contributions were made by staff in DEP's Watershed Assessment Section and Central Regional Operation Center (ROC). DEP also recognizes the substantial support and assistance of the St. Johns River Water Management District (SJRWMD), especially Dr. Rolland Fulton, and its contributions towards understanding the watershed modeling approach and the issues, history, and processes at work in the Lake Roberts watershed.

Editorial assistance was provided by Erin Rasnake, Ken Weaver, Kevin O'Donnell, Xueqing Gao, Garry Payne, Jessica Mostyn, Mary Paulic, and Linda Lord.

For additional information on the watershed management approach and impaired waters in the Ocklawaha Basin, contact:

Mary Paulic
Florida Department of Environmental Protection
Water Quality Restoration Program Watershed Planning and Coordination Section
Watershed Planning and Coordination Section
2600 Blair Stone Road, Mail Station 3565
Tallahassee, FL 32399-2400
Email: [Mary Paulic](mailto:Mary.Paulic@floridadep.gov)
Phone: (850) 245-8560; fax: (850) 245-8434

Access to all data used in the development of this report can be obtained by contacting

Woo-Jun Kang
Florida Department of Environmental Protection
Watershed Evaluation and TMDL Section
Water Quality Evaluation and TMDL Program
2600 Blair Stone Road, Mail Station 3565
Tallahassee, FL 32399-2400
Email: [Woo-Jun Kang](mailto:Woo-Jun.Kang@floridadep.gov)
Phone: (850) 245-8437; fax: (850) 245-8434

Contents

Chapter 1: Introduction	9
1.1 Purpose of Report	9
1.2 Identification of Waterbody.....	9
1.3 Background	10
Chapter 2: Description of Water Quality Problem	12
2.1 Statutory Requirements and Rulemaking History	12
2.2 Information on Verified Impairment.....	12
Chapter 3. Description of Applicable Water Quality Standards and Targets	14
3.1 Classification of the Waterbody and Criteria Applicable to the TMDLs.....	14
3.2 Numeric Interpretation of the Narrative Nutrient Criterion	14
Chapter 4: Assessment of Sources.....	17
4.1 Types of Sources.....	17
4.2 Potential Nutrient Sources in the Lake Roberts Watershed.....	18
4.2.1 Point Sources	18
4.2.2 Nonpoint Sources	18
Chapter 5: Determination of Assimilative Capacity.....	39
5.1 Determination of Loading Capacity.....	39
5.2 Water Quality Trends for Lake Roberts	39
5.3 Lake Roberts Water Quality Modeling	45
5.3.1 BATHTUB Overview	45
5.3.2 BATHTUB Inputs	46
5.3.3 BATHTUB Calibration	55
5.3.4 Natural Background Conditions To Determine Natural Levels of Chlorophyll a, TN, and TP.....	65
5.3.5 Load Reduction Scenarios To Determine the TMDLs.....	66
Chapter 6: Determination of the TMDLs.....	73
6.1 Expression and Allocation of the TMDLs	73
6.2 Load Allocation (LA).....	74
6.3 Wasteload Allocation (WLA).....	74
6.3.1 NPDES Wastewater Discharges.....	74
6.3.2 NPDES Stormwater Discharges	74
6.4 Margin of Safety (MOS).....	75
Chapter 7: Next Steps: Implementation Plan Development and Beyond.....	76
7.1 Implementation Mechanisms	76
7.2 Basin Management Action Plans	76
7.3 Implementation Considerations for Lake Roberts	77

References..... 78

Appendices..... 82

Appendix A: Summary of Information Supporting the TMDLs as Site-Specific Interpretations of the Narrative Nutrient Criterion for Lake Roberts 82

Appendix B: Background Information on Federal and State Stormwater Programs..... 86

Appendix C: Monthly Water Budget for Lake Roberts, 2000–12..... 88

Appendix D: Study for Estimating Groundwater Seepage and Nitrogen Loads from Septic Systems 93

Appendix E: Important Links 94

List of Tables

Table 2.1.	Summary of annual TSI values for Lake Roberts during the verified period.....	13
Table 3.1.	Chlorophyll <i>a</i> , TN, and TP criteria for Florida lakes (Subparagraph 62-302.531[2][b]1., F.A.C.).....	15
Table 4.1.	SJRWMD 16 land uses and their corresponding acreage in the Lake Roberts watershed	20
Table 4.2.	Acreage of hydrologic soil groups in the Lake Roberts watershed	25
Table 4.3.	Annual rainfall to the Lake Roberts watershed	27
Table 4.4.	Runoff volume (ac-ft/yr) from the Lake Roberts watershed	28
Table 4.5.	EMCs of TN and TP for different land use types	29
Table 4.6.	Dissolved fraction of TN and TP concentrations for different land uses	31
Table 4.7.	Runoff TP annual loads (kg/yr) from the Lake Roberts watershed.....	33
Table 4.8.	Runoff TN annual loads (kg/yr) from the Lake Roberts watershed	34
Table 5.1.	Water quality station in Lake Roberts over the period of record, 1994–2013.....	39
Table 5.2.	Summary of statistics of water quality parameters in Lake Roberts observed during the assessment (planning and verified) period, 2000–12.....	42
Table 5.3.	Annual means and standard deviation (± 1 sigma standard deviation) of chlorophyll <i>a</i> , TN, and TP and TN/TP ratios in Lake Roberts, 2000–12.....	42
Table 5.4.	Annual means of morphologic characteristics of Lake Roberts, 2000–12	50
Table 5.5.	Annual total evaporation and precipitation for Lake Roberts, 2000–12.....	51
Table 5.6.	Direct atmospheric deposition of TN and TP to Lake Roberts, 2000–12.....	52
Table 5.7.	Calculated groundwater seepage inflow (ac-ft/yr) to Lake Roberts, 2000–12	58
Table 5.8.	Calibrated TP mass balance for Lake Roberts, 2000–12.....	63
Table 5.9.	Calibrated TN mass balance for Lake Roberts, 2000–12	64
Table 5.10.	Load reduction scenarios for TP under existing, 35 % reduction, and TMDL conditions (32 % reduction).....	70
Table 5.11.	Load reduction scenarios for TN under existing, 30 % reduction, and TMDL conditions (20 % reduction).....	70
Table 5.12.	TMDL TP and TN loads to achieve the water quality targets for Lake Roberts.....	72
Table 6.1.	TMDL components for Lake Roberts.....	74
Table A-1.	Spatial extent of the waterbody where site-specific numeric interpretations of the narrative nutrient criterion will apply	82
Table A-2.	Default NNC, site-specific interpretations of the narrative criterion developed as TMDL targets, and data used to develop the site-specific interpretation of the narrative criterion	83
Table A-3.	History of nutrient impairment, quantitative indicators of use support, and methodologies used to develop the site-specific interpretation of the narrative criterion	84
Table A-4.	Site-specific interpretation of the narrative criterion and protection of designated use of downstream segments	85

Table A-5. Public participation and legal requirements of rule adoption85

List of Figures

Figure 1.1. Geographic location of Lake Roberts in central Florida and major geopolitical features in the area 11

Figure 4.1. Lake Roberts land use spatial distribution, 2004.....21

Figure 4.2. Lake Roberts land use spatial distribution, 2009.....22

Figure 4.3. Lake Roberts soil hydrologic groups (NRCS 2010).....24

Figure 4.4. Percent TP runoff loads from different land uses in the Lake Roberts watershed. LDR and MDR represent low- and high-density residential, and LDC and HDC indicate low- and high-density commercial, respectively.35

Figure 4.5. Percent TN runoff loads from different land uses in the Lake Roberts watershed. LDR and MDR represent low- and high-density residential, and LDC and HDC indicate low- and high-density commercial, respectively.35

Figure 5.1. Location of water quality station in Lake Roberts.....40

Figure 5.2. Long-term trend concentrations of chlorophyll *a*, TN, and TP and TN/TP ratios in Lake Roberts, 1994–201241

Figure 5.3. Monthly variations of chlorophyll *a*, TN, and TP and TN/TP ratios in Lake Roberts, 2000–12. Error bars represent a 1-sigma standard deviation.44

Figure 5.4. Bathymetric map generated for Lake Roberts using ArcGIS. Each contour line represents a 0.5-m depth interval.....48

Figure 5.5a. Relationship of depth versus surface area for Lake Roberts. Solid line is a best-fit polynomial line.49

Figure 5.5b. Relationship of depth versus cumulative volume for Lake Roberts. Solid line is a best-fit polynomial line.49

Figure 5.6. Locations of seepage meters installed in Lake Roberts in August 201356

Figure 5.7. Seepage rate and standard deviation averaged from monthly monitoring data collected from each station57

Figure 5.8. Seepage TN and standard deviation averaged from monthly monitoring data collected from each station57

Figure 5.9. Seepage TP and standard deviation averaged from monthly monitoring data collected from each station57

Figure 5.10. Relationship between annual total rainfall versus the sum of annual seepage-inflow minus annual lake outflow ($S_{in} - L_{out}$), 2000–12.....58

Figure 5.11. Relationship between annual total rainfall versus the sum of annual seepage inflow minus annual lake outflow ($S_{in} - L_{out}$), 2000–1259

Figure 5.12. Calibration of simulated annual TP (blue bars) with observed annual TP (orange bars) in Lake Roberts, 2000–12.....60

Figure 5.13. Box and whisker plot of simulated versus observed TP in Lake Roberts. The red line and diamond represent a long-term mean with 95 % confidence levels.61

Figure 5.14. Calibration of simulated annual TN (blue bars) with observed annual TN (orange bars) in Lake Roberts, 2000–12.....61

Figure 5.15. Box and whisker plot of simulated versus observed TN in Lake Roberts. The red line and diamond represent a long-term mean with 95 % confidence levels.62

Figure 5.16. Calibration of simulated annual chlorophyll *a* (blue bars) with observed annual chlorophyll *a* (orange bars) in Lake Roberts, 2000–12.....62

Figure 5.17. Box and whisker plot of simulated versus observed chlorophyll *a* in Lake Roberts. The red line and diamond represent a long-term mean with 95 % confidence levels.63

Figure 5.18. Percent contribution of average annual TP loads from various pathways to Lake Roberts, 2000–12.....64

Figure 5.19. Percent contribution of average annual TN loads from various pathways to Lake Roberts, 2000–12.....65

Figure 5.20. Linear relationships between AGMs and annual average concentrations of TP (top) and TN (bottom) used for lake NNC development. The dataset (circles) obtained from the observed data for Lake Roberts were plotted along the regression lines derived from the lake NNC dataset.....68

Figure 5.21. AGMs of chlorophyll *a*, TN, and TP for existing (blue bars) versus natural background (orange bars) conditions, 2000–12. Gray and yellow dashed lines represent the long-term averages of existing and natural background conditions, respectively.69

Figure 5.22. Simulated AGMs of TP (top) and TN (bottom) for existing (blue bars), natural background (orange bars), and TMDL conditions (green bars). The red line represents the water quality targets of TP and TN in $\mu\text{g/L}$ for Lake Roberts. 71

Figure 5.23. Simulated AGMs of chlorophyll *a* for existing (blue bars), natural background (orange bars), and TMDL conditions (green bars). The red line represents the chlorophyll *a* target of $20 \mu\text{g/L}$ for Lake Roberts.72

Websites

Florida Department of Environmental Protection

[TMDL Program](#)

[Identification of Impaired Surface Waters Rule](#)

[Florida STORET Program](#)

[2016 Integrated Report](#)

[Criteria for Surface Water Quality Classifications](#)

[Basin Management Action Plans](#)

U.S. Environmental Protection Agency

[Region 4: TMDLs in Florida](#)

[National STORET Program](#)

Chapter 1: Introduction

1.1 Purpose of Report

This report presents the total maximum daily loads (TMDLs) for nutrients for Lake Roberts in the Ocklawaha River Basin. The TMDLs will constitute the site-specific numeric interpretation of the narrative nutrient criterion set forth in Paragraph 62-302.530(47)(b), Florida Administrative Code (F.A.C.), that will replace the otherwise applicable numeric nutrient criteria (NNC) in Subsection 62-302.531(2), F.A.C., for this particular water. The lake was verified as impaired for nutrients due to elevated annual average Trophic State Index (TSI) values, and was included on the Verified List of impaired waters for the Ocklawaha River Basin adopted by Secretarial Order on February 12, 2013.

According to the 1999 Florida Watershed Restoration Act (FWRA) (Chapter 99-223, Laws of Florida), once a waterbody is included on the Verified List, a TMDL must be developed. The purpose of these TMDLs is to establish the allowable loadings of pollutants to Lake Roberts that would restore the waterbody so that it meets its applicable water quality criteria for nutrients.

1.2 Identification of Waterbody

Lake Roberts is located in central Florida 5 miles west of Orlando and 2 miles south of Winter Garden in Orange County, within the Ocklawaha Basin and the Lake Apopka Planning Unit (**Figure 1.1**). Lake Roberts is a 107-acre lake with an average lake elevation of 109 feet National Geodetic Vertical Datum (NGVD). The lake is located in the Apopka Upland Lake Region (Region 75-16), which consists primarily of residual sandhills modified by karst processes, with many small lakes and scattered sinkholes (Griffith et al. 1997).

The elevation of the Lake Roberts watershed ranges from 110 feet immediately adjacent to the lake to 120 feet along the watershed boundary. The major sources of water to the lake include surface runoff from the watershed, seepage flow from groundwater, and direct rainfall onto the lake surface. The lake also receives flow from Lake Reaves, located northeast of Lake Roberts, and connects with Lake Roberts through the intermediary wetland. There may be flow to the lake through a conveyance connected to a retention pond located in the northwest portion of the lake, depending on the surface elevation of Lake Roberts. The retention pond catches sheet flow from a residential area. The lake is surrounded mainly by residential areas and wetlands.

Based on lake stage data collected for the period from 1971 to 2004, the long-term average stage of the lake is 109 feet National Geodetic Vertical Datum (NGVD). NGVD. Groundwater influence on the lake may primarily come from the surficial aquifer. Long-term average annual rainfall, based on Doppler radar-converted rainfall data for the period from 2000 through 2012 provided by the St. Johns River Water Management District (SJRWMD), is 48 inches/year

(in/yr). The annual average air temperature, based on data collected from 2000 through 2012 from a weather station located at Orlando International Airport, is 23° C. The summer maximum temperature ranges between 35° and 37° C., and the winter minimum temperature ranges between -4° and 1° C.

For assessment purposes, the Florida Department of Environmental Protection (DEP) has divided the Ocklawaha River Basin into water assessment polygons with a unique **waterbody identification (WBID)** number for each watershed or stream reach. Lake Roberts is WBID 2872A.

1.3 Background

This report was developed as part of DEP's watershed management approach for restoring and protecting state waters and addressing TMDL Program requirements. The watershed approach, which is implemented using a cyclical management process that rotates through the state's 52 river basins over a 5-year cycle, provides a framework for implementing the TMDL Program-related requirements of the 1972 federal Clean Water Act and the FWRA.

A TMDL represents the maximum amount of a given pollutant that a waterbody can assimilate and still meet water quality standards, including its applicable water quality criteria and its designated uses. TMDLs are developed for waterbodies that are verified as not meeting their water quality standards, and provide important water quality restoration goals that will guide restoration activities.

This TMDL report will be followed by the development and implementation of a restoration plan to reduce the amount of nutrients that caused the verified impairment of Lake Roberts. Restoration activities will depend heavily on the active participation of the City of Winter Garden, Orange County, residents living within the watershed, businesses within the watershed, and other stakeholders. DEP will work with these organizations and individuals to undertake or continue reductions in the discharge of pollutants and achieve the established TMDLs for the impaired waterbody.

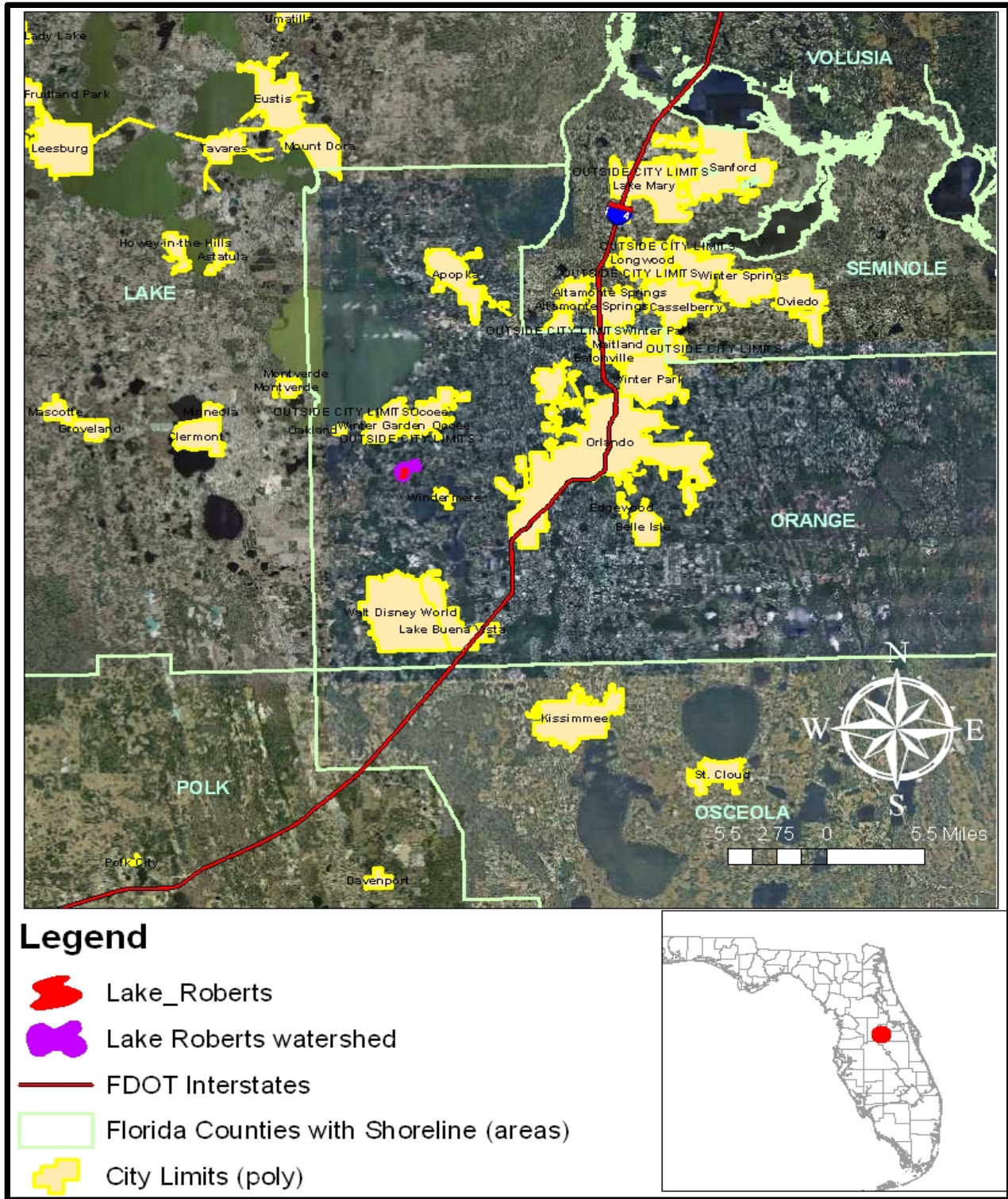

Figure 1.1. Geographic location of Lake Roberts in central Florida and major geophysical features in the area

Chapter 2: Description of Water Quality Problem

2.1 Statutory Requirements and Rulemaking History

Section 303(d) of the Clean Water Act requires states to submit to the U.S. Environmental Protection Agency (EPA) a list of surface waters that do not meet applicable water quality standards (impaired waters) and establish a TMDL for each pollutant source in each of these impaired waters on a schedule. DEP has developed these lists, commonly referred to as 303(d) lists, since 1992. The list of impaired waters in each basin is also required by the FWRA (Subsection 403.067[4], Florida Statutes [F.S.]), and the list is amended annually to include updates for each basin statewide.

Florida's 1998 303(d) list included 41 waterbodies in the Ocklawaha River Basin. However, the FWRA (Section 403.067, F.S.) stated that all previous Florida 303(d) lists were for planning purposes only and directed DEP to develop, and adopt by rule, a new science-based methodology to identify impaired waters. After a long rulemaking process, the Environmental Regulation Commission adopted the new methodology as Chapter 62-303, F.A.C. (Identification of Impaired Surface Waters Rule, or IWR), in April 2001. The list of waters for which impairments have been verified using the methodology in the IWR is referred to as the Verified List.

2.2 Information on Verified Impairment

DEP used the IWR to assess water quality impairments in the Ocklawaha River Basin and verified that Lake Roberts was impaired for nutrients based on the fact that in the verified period (January 1, 2005–June 30, 2012), annual average TSI values exceeded the applicable threshold of 60 in 2005, 2008, and 2009 (**Table 2.1**).

The individual total nitrogen (TN) and total phosphorus (TP) ratios from January 2005 to June 2012 were calculated. If the median value of all the TN/TP ratios over the period of record was less than 10, nitrogen would be identified as the limiting nutrient, and if the median value of all the TN/TP ratios was greater than 30, phosphorus would be identified as the limiting nutrient. Both nitrogen and phosphorus would be identified as limiting nutrients if the median TN/TP ratio was between 10 and 30. For Lake Roberts, the median TN/TP ratio during the period was 24, suggesting that the phytoplankton community is colimited by nitrogen and phosphorus in the lake.

Table 2.1. Summary of annual TSI values for Lake Roberts during the verified period

PCU = Platinum cobalt units

NA = Not available

*In this report, chlorophyll *a* (chl_a) refers to corrected chlorophyll *a* unless otherwise specified.

Year	Mean Color (PCU)	TSI Threshold	Calculated TSI Based on Measured TN, TP, and Chlorophyll <i>a</i>*	Exceedance
2005	115	60	62	Yes
2006	56	60	NA	NA
2007	55	60	55	No
2008	62	60	62	Yes
2009	63	60	65	Yes
2010	77	60	60	No

Chapter 3. Description of Applicable Water Quality Standards and Targets

3.1 Classification of the Waterbody and Criteria Applicable to the TMDLs

Florida's surface waters are protected for six designated use classifications, as follows:

Class I	Potable water supplies
Class II	Shellfish propagation or harvesting
Class III	Fish consumption; recreation, propagation, and maintenance of a healthy, well-balanced population of fish and wildlife
Class III–Limited	Fish consumption; recreation or limited recreation; and/or propagation and maintenance of a limited population of fish and wildlife
Class IV	Agricultural water supplies
Class V	Navigation, utility, and industrial use (there are no state waters currently in this class)

Lake Roberts is a Class III waterbody, with a designated use of recreation, propagation, and maintenance of a healthy, well-balanced population of fish and wildlife. The Class III water quality criteria applicable to the impairment addressed by these TMDLs are for nutrients.

3.2 Numeric Interpretation of the Narrative Nutrient Criterion

Lake Roberts, located in the Ocklawaha River Basin, was verified impaired for nutrients in the Group 1, Cycle 3 assessment, because the lake exceeded the annual average TSI threshold of 60. Florida adopted NNC for lakes, spring vents, and streams in 2011 that were approved by the EPA in 2012 and became effective on October 27, 2014. **Table 3.1** lists the NNC for Florida lakes specified in Subparagraph 62-302.531(2)(b)1., F.A.C.

Based on Subparagraph 62-302.531(2)(b)1., F.A.C., if a given lake has a long-term geometric mean color greater than 40 PCU, or if the long-term geometric mean color of the lake is less than 40 PCU but the long-term geometric mean of alkalinity (represented as calcium carbonate [CaCO₃]) of the lake is greater than 20 milligrams per liter (mg/L), the chlorophyll *a* (Chl*a*) criterion is 20 micrograms per liter (µg/L). For a lake with a long-term geometric mean color less than 40 PCU and a long-term geometric mean alkalinity less than 20 mg/L CaCO₃, the Chl*a* criterion is 6 µg/L. For a lake to comply with the Chl*a* criterion, the AGM of Chl*a* should not exceed the criterion more than once in any consecutive 3-year period. These Chl*a* criteria were

established by taking into consideration the results of paleolimnological studies, expert opinions, biological responses, user perceptions, and Chl a concentrations in a set of carefully selected reference lakes.

Table 3.1. Chlorophyll a , TN, and TP criteria for Florida lakes (Subparagraph 62-302.531[2][b]1., F.A.C.)

AGM = Annual geometric mean

¹ For lakes with color > 40 PCU in the West Central Nutrient Watershed Region, the maximum TP limit shall be the 0.49 mg/L TP streams threshold for the region.

Lake Group Long-Term Geometric Mean Color and Alkalinity	Lake Group AGM Chlorophyll a	Minimum NNC AGM TP	Minimum NNC AGM TN	Maximum NNC AGM TP	Maximum NNC AGM TN
>40 PCU	20 μ g/L	0.05 mg/L	1.27 mg/L	0.16 mg/L ¹	2.23 mg/L
\leq 40 PCU and > 20 mg/L CaCO ₃	20 μ g/L	0.03 mg/L	1.05 mg/L	0.09 mg/L	1.91 mg/L
\leq 40 PCU and \leq 20 mg/L CaCO ₃	6 μ g/L	0.01 mg/L	0.51 mg/L	0.03 mg/L	0.93 mg/L

If there are sufficient data to calculate the AGM Chl a and the mean does not exceed the Chl a criterion for the lake type listed in **Table 3.1**, then the TN and TP criteria for that calendar year are the AGMs of lake TN and TP samples, subject to the minimum and maximum limits in the table. However, for lakes with color > 40 PCU in the West Central Nutrient Watershed Region, the maximum TP criterion is the 0.49 mg/L TP streams threshold for the region. If there are insufficient data to calculate the AGM Chl a for a given year, or the AGM Chl a concentration exceeds the criterion specified in **Table 3.1** for the lake type, then the TN and TP criteria are the minimum values in the table.

For the purpose of Subparagraph 62-302.531(2)(b)1., F.A.C., color is assessed as true color and should be free from turbidity. Lake color and alkalinity are the long-term geometric mean, based on a minimum of 10 data points over at least 3 years with at least 1 data point in each year. If insufficient alkalinity data are available, long-term geometric mean specific conductance values can be used, with a value of < 100 micromhos per centimeter (μ mhos/cm) used to estimate the 20 mg/L CaCO₃ alkalinity concentration until alkalinity data are available.

DEP also assessed the data for Lake Roberts using the NNC. Based on the data retrieved from the IWR Database, the long-term geometric mean color value for Lake Roberts is 62 PCU, which is higher than the 40 PCU value that distinguishes high-color lakes from clear-water lakes. Lake Roberts is thus considered a high-color lake, and the Chl a criterion applicable to Lake Roberts is 20 μ g/L.

Lake Roberts does not meet the NNC based on this preliminary analysis of the available data and therefore remains impaired for nutrients. The nutrient TMDLs presented in this report, upon adoption into Rule 62-304, F.A.C., will constitute site-specific numeric interpretations of the

narrative nutrient criterion set forth in Paragraph 62-302.530(47)(b), F.A.C., that will replace the otherwise applicable NNC in Subsection 62-302.531(2), F.A.C., for this particular water, pursuant to Paragraph 62-302.531(2)(a), F.A.C.

The Water Quality Standards template document in **Appendix A** provides the relevant TMDL information, including documentation that the TMDLs provide for the attainment and maintenance of water quality standards in downstream waters (pursuant to Subsection 62-302.531[4], F.A.C.), to support using the TMDL nutrient targets as the site-specific numeric interpretations of the narrative nutrient criterion. The targets used in TMDL development are designed to restore surface water quality to meet a waterbody's designated use. The criteria are based on scientific information used to establish specific levels of water quality constituents that protect aquatic life and human health for particular designated use classifications.

DEP developed the lake NNC based on an evaluation of a response variable, *Chla*, and stressor variables, TN and TP, to develop water quality criteria that are protective of designated uses (DEP 2012). To establish the nutrient targets for the Lake Roberts TMDLs, DEP used the 20 µg/L *Chla* criterion as the target because this level is considered protective of the designated use of high-color lakes. Based on the available information, there is nothing unique about Lake Roberts' characteristics that would make the use of the *Chla* threshold of 20 µg/L inappropriate for the lake.

To determine the TMDLs, DEP used calibrated watershed and receiving waterbody models to establish the in-lake TN and TP concentrations and associated watershed loads to an in-lake *Chla* concentration of 20 µg/L. **Chapter 5** contains details on the simulation of the in-lake TN and TP targets that achieved this concentration. Simulated TN and TP target concentrations were checked against the model-simulated natural background TN and TP concentrations to avoid abating the natural background condition. Based on the calibrated model simulation, as explained in **Chapter 5**, the final in-lake TN and TP targets needed to achieve the 20 µg/L *Chla* concentration are 0.044 mg/L for TP and 1.02 mg/L for TN, which are AGMs not to be exceeded in any year.

Chapter 4: Assessment of Sources

4.1 Types of Sources

An important part of the TMDL analysis is the identification of pollutant source categories, source subcategories, or individual sources of the pollutant of concern in the target watershed and the amount of pollutant loading contributed by each of these sources. Sources are broadly classified as either point sources or nonpoint sources. Historically, the term "point sources" has meant discharges to surface waters that typically have a continuous flow via a discernable, confined, and discrete conveyance, such as a pipe. Domestic and industrial wastewater treatment facilities (WWTFs) are examples of traditional point sources. In contrast, the term "nonpoint sources" was used to describe intermittent, rainfall-driven, diffuse sources of pollution associated with everyday human activities, including runoff from urban land uses, agriculture, silviculture, and mining; discharges from failing septic systems; and atmospheric deposition.

However, the 1987 amendments to the Clean Water Act redefined certain nonpoint sources of pollution as point sources subject to regulation under the EPA's National Pollutant Discharge Elimination System (NPDES) Program. These nonpoint sources included certain urban stormwater discharges, such as those from local government master drainage systems, construction sites over five acres, and a wide variety of industries (see **Appendix B** for background information on the federal and state stormwater programs).

To be consistent with Clean Water Act definitions, the term "point source" is used to describe traditional point sources (such as domestic and industrial wastewater discharges) **and** stormwater systems requiring an NPDES stormwater permit when allocating the pollutant load reductions required by a TMDL (see **Section 6.1 on Expression and Allocation of the TMDLs**). However, the methodologies used to estimate nonpoint source loads do not distinguish between NPDES and non-NPDES stormwater discharges, and as such, this source assessment section does not make any distinction between the two types of stormwater.

4.2 Potential Nutrient Sources in the Lake Roberts Watershed

4.2.1 Point Sources

4.2.1.1 Wastewater Point Sources

When these TMDLs were being developed, no NPDES-permitted wastewater facilities discharging to Lake Roberts were identified in the watershed.

4.2.1.2 Municipal Separate Storm Sewer System (MS4) Permittees

In the Lake Roberts watershed, the stormwater collection systems owned and operated by Orange County, in conjunction with the Florida Department of Transportation (FDOT) District 5, are covered by an NPDES Phase I MS4 permit (FLS000011). The City of Winter Garden is a co-permittee in the MS4 permit, and a portion of the watershed is situated within the city limits.

4.2.2 Nonpoint Sources

Nutrient loadings to Lake Roberts are primarily generated from nonpoint sources. Nonpoint sources addressed in this analysis primarily include loadings from surface runoff, groundwater seepage entering the lake, and precipitation directly onto the lake surface.

In this TMDL analysis, nutrient loadings from the watershed were estimated by multiplying the runoff volume by the TN and TP event mean concentrations (EMCs). The runoff volume from the watershed was primarily estimated using the U.S. Department of Agriculture (USDA) Natural Resources Conservation Service (NRCS) curve number approach, which estimates runoff volume by taking into consideration land use type, soil type, the imperviousness of the watershed, and the antecedent moisture condition of the soil. Curve numbers ranging between 20 and 100 were assigned to different land use–soil combinations to represent different runoff potentials for different combinations. Rainfall is the driving force of the curve number approach.

The land use information in this analysis was obtained from the SJRWMD land use shapefiles. Because the nutrient loading simulation covers a relatively long period from 2000 through 2012, land use geographic information system (GIS) shapefiles from two years were used in the loading estimation: the 2004 land use shapefile was used to estimate annual nutrient loads for the period from 2000 through 2005, and the 2009 land use shapefile was used to simulate nutrient loads from 2006 through 2012. Soil hydrologic characteristics for the watershed were obtained from the NRCS 2010 Soil Survey Geographic (SSURGO) Database GIS shapefile.

4.2.2.1 Land Uses

Land use is one of the most important factors in estimating nutrient loadings from the Lake Roberts watershed. Nutrients can be flushed into the receiving water through surface runoff and

stormwater conveyance systems during stormwater events. Both human and natural land use areas generate nutrients. However, human land uses typically generate more nutrient loads per unit of land surface area than natural lands can produce.

The information used in developing these TMDLs was obtained from the SJRWMD's 2004 and 2009 land use shapefiles. These define land use types based on the land use classification system adopted in the Florida Land Use and Land Cover Classification System (FLUCCS) (FDOT 1999). To estimate nutrient loads from the Lake Roberts watershed, the detailed land use types defined by the Level III FLUCCS code in these shapefiles were aggregated based on a 16-land use classification system used by the SJRWMD in developing the pollutant load reduction goals (PLRGs) for seven major lakes in the Upper Ocklawaha River Basin (Fulton et al. 2004). **Table 4.1** lists these land use types and their corresponding acreages in the Lake Roberts watershed for 2004 and 2009, and the change in acreage of these land uses between 2004 and 2009. **Figures 4.1** and **4.2** show the spatial distribution of different land use types in the Lake Roberts watershed in 2004 and 2009, respectively.

The total area of the Lake Roberts watershed is 488 acres, and the area of the lake itself is 107 acres, based on the SJRWMD 2004 land use classification. The dominant land use type in 2004 was wetlands, which covered 120 acres and accounted for 24.7 % of the total watershed area. The second largest land use type in 2004 was medium-density residential, which comprised 108 acres and accounted for 22.1 % of the watershed area. The third largest land use type was low-density residential, occupying 107 acres and accounting for 21.9 % of the total watershed. Overall, human land uses, including all the residential, commercial, industrial, and agricultural areas, occupied 326 acres, or 67 %, of the total watershed area. Among these human uses, 59.5 % were urban lands, including all the residential, commercial, industrial, mining, and open lands and recreational areas, and 7.2 % are agricultural. In contrast, natural land uses, including forest/rangeland, water, and wetlands, occupied 162 acres, comprising 33 % of the total watershed area.

Table 4.1. SJRWMD 16 land uses and their corresponding acreage in the Lake Roberts watershed

NA = Not applicable

SJRWMD Land Use	2004 Land Use (acres)	2004 Land Use (%)	2009 Land Use (acres)	2009 Land Use (%)	Difference between 2009 and 2004 (acres)	% Difference
Low-density residential	107.1	21.9	39.5	8.1	-67.6	-171
Medium-density residential	107.7	22.1	211.2	43.3	103.5	49
High-density residential	0.0	0.0	0.0	0.0	NA	NA
Low-density commercial	1.0	0.2	2.2	0.4	1.1	52
High-density commercial	0.4	0.1	0.4	0.1	0.0	0
Industrial	0.0	0.0	0.0	0.0	NA	NA
Mining	0.0	0.0	0.0	0.0	NA	NA
Open land/recreational	74.4	15.2	39.0	8.0	-35.4	-91
Pasture	24.7	5.1	24.7	5.1	0.0	0
Cropland	0.0	0.0	0.0	0.0	NA	NA
Tree crops	10.8	2.2	10.7	2.2	-0.1	-1
Feeding operations	0.0	0.0	0.0	0.0	NA	NA
Other agriculture	0.0	0.0	0.0	0.0	NA	NA
Forest/rangeland	12.2	2.5	11.3	2.3	-0.8	-7
Water	29.4	6.0	41.9	8.6	12.5	30
Wetlands	120.5	24.7	107.4	22.0	-13.2	-12
Total	488.2	100	488.2	100		

Compared with the land use distribution in 2004, the pattern in the Lake Roberts watershed had changed significantly by 2009. The largest change was a 104-acre increase in medium-density residential, from 108 acres in 2004 to 211 acres in 2009, a 49 % increase. At the same time, low-density residential decreased 68 acres, going from 107 acres to 40 acres, or a 171 % decrease. The acreage of the other land use types in 2009, including open land/recreational, forest/rangeland, and wetlands, decreased by 91 %, 7 %, and 12 %, respectively.

Overall, in 2009, human land use areas occupied 328 acres of the watershed, accounting for 67 % of the total area. Among these human land uses, 60 % were urban lands and 7.2 % were agricultural. Natural land uses, including forest/rangeland, water, and wetlands, occupied 161 acres, or 33 % of the total watershed area, showing no changes between 2004 and 2009. Human land use types were predominant in both 2004 and 2009, with urban land use predominating in these areas. It should be noted that the SJRWMD's land use classification for PLRG estimates included golf course and other open areas, which were classified as open land/recreational.

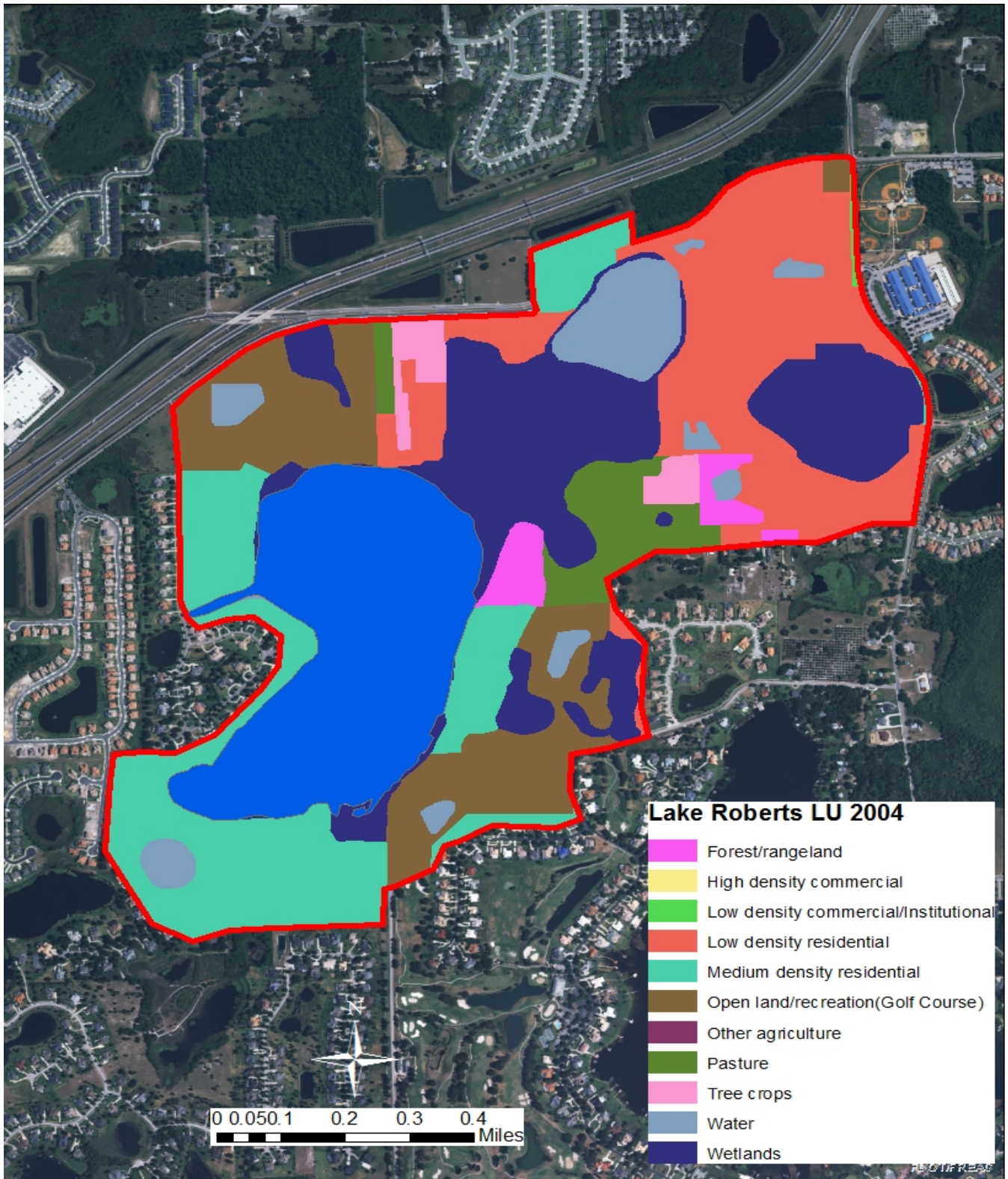

Figure 4.1. Lake Roberts land use spatial distribution, 2004

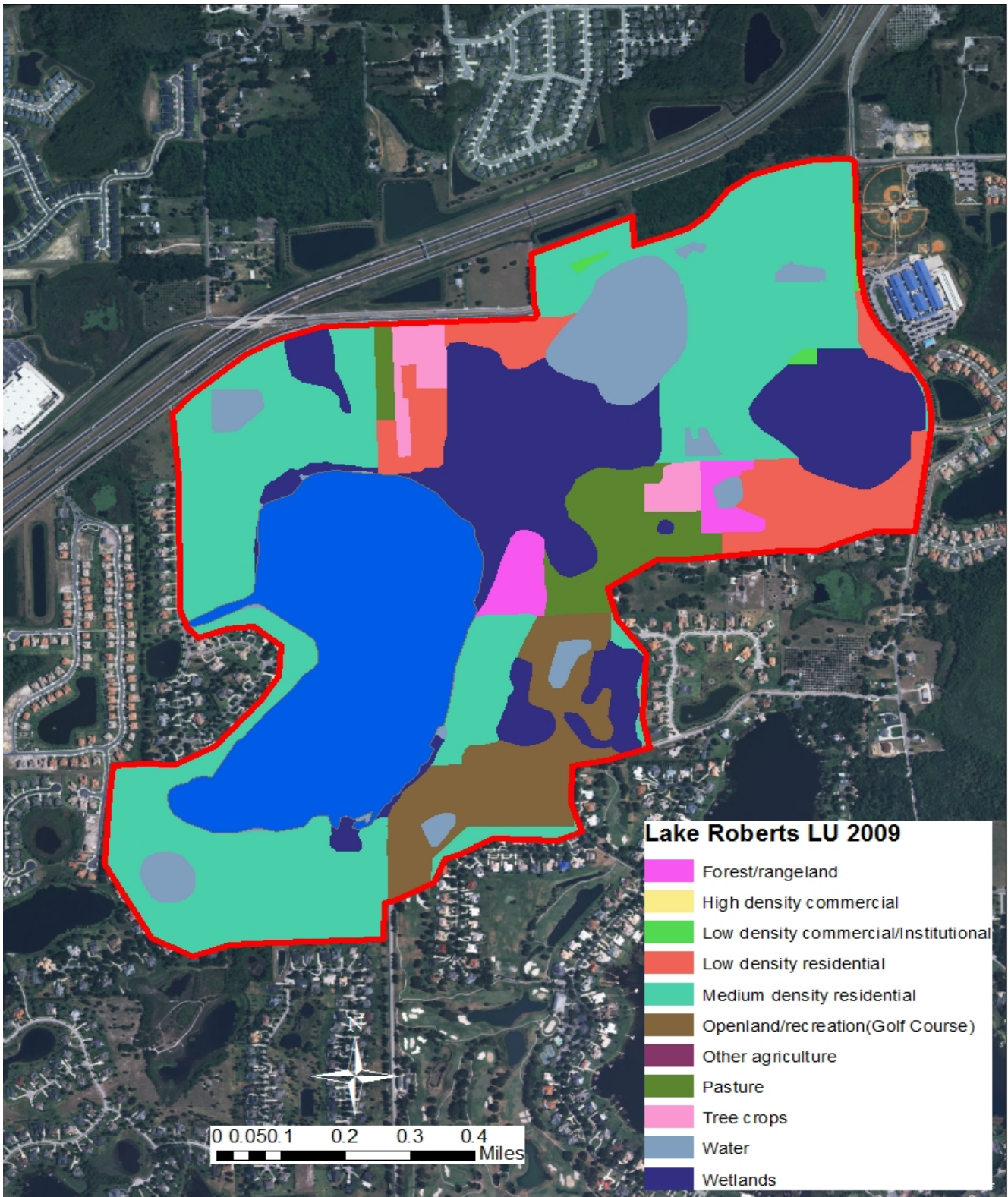

Figure 4.2. Lake Roberts land use spatial distribution, 2009

4.2.2.2 Hydrologic Soil Groups

The hydrologic characteristics of soil can significantly influence the capability of a watershed to hold rainfall or produce surface runoff. Soils are generally classified as one of four major types, as follows, based on their hydrologic characteristics (Viessman et al. 1989):

- **Type A soil (low runoff potential):** Soils having high infiltration rates even if thoroughly wetted and consisting chiefly of deep, well-drained to excessively drained sands or gravels. These soils have a high rate of water transmission.
- **Type B soil:** Soils having moderate infiltration rates if thoroughly wetted and consisting chiefly of moderately deep to deep, moderately well-drained to well-drained soils with moderately fine to moderately coarse textures. These soils have a moderate rate of water transmission.
- **Type C soil:** Soils having slow infiltration rates if thoroughly wetted and consisting chiefly of soils with a layer that impedes the downward movement of water, or soils with moderately fine to fine texture. These soils have a slow rate of water transmission.
- **Type D soil (high runoff potential):** Soils having very slow infiltration rates if thoroughly wetted and consisting chiefly of clay soils with a high swelling potential, soils with a permanent high water table, soils with a clay pan or clay layer at or near the surface, and shallow soils over nearly impervious materials. These soils have a very slow rate of water transmission.

The soil hydrologic characteristics of the Lake Roberts watershed used in this TMDL analysis were based on the soil hydrologic classifications in the NRCS 2010 SSURGO GIS shapefile. **Figure 4.3** shows the spatial distribution of soil hydrologic groups in the Lake Robert watershed. Type A and A/D soils were predominant. Small amounts of B/D soil were present from northwest to southwest of Lake Roberts, in some wetland areas, and also in the southeast corner of the watershed. Type A/D soil has Type A soil characteristics when unsaturated but behaves like Type D soil when saturated. In this analysis, A/D soil was treated as D soil when assigning the curve number. Soil types in some portions of the watershed were not defined in the SSURGO shapefile (Soil Type X). Most were located in the areas covered by waterbodies or wetlands.

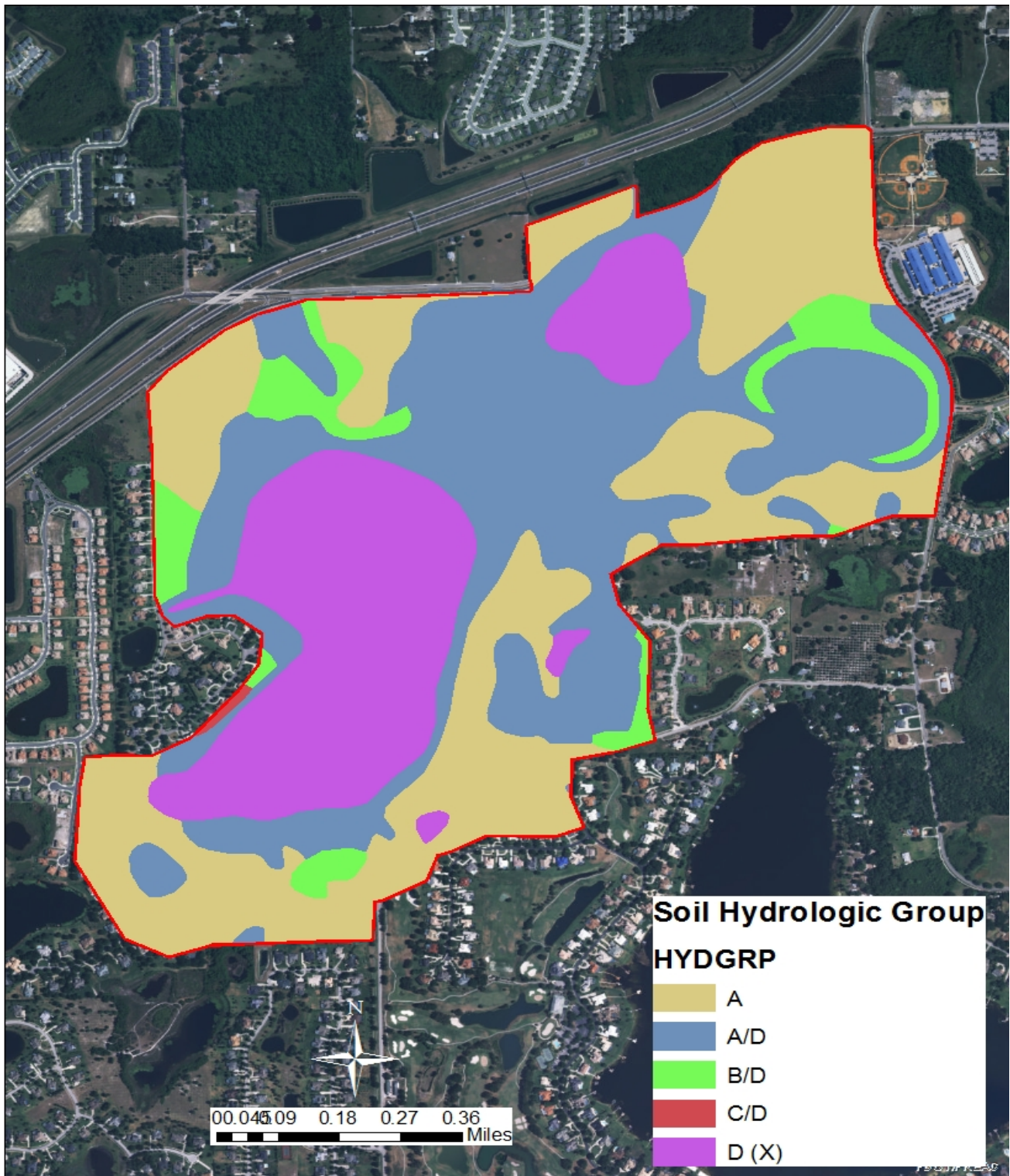

Figure 4.3. Lake Roberts soil hydrologic groups (NRCS 2010)

In this TMDL analysis, these undefined soils were all considered Type D soil when assigning the curve number. This is reasonable because soils in waterbodies and wetlands typically show a low potential for water infiltration. **Table 4.2** lists the soil hydrologic groups in the Lake Roberts watershed and their corresponding acreages.

Table 4.2. Acreage of hydrologic soil groups in the Lake Roberts watershed

Soil Hydrologic Group	Acreage	% Acreage
A	208	42.5
A/D	217	44.5
B/D	35	7.2
C/D	1	0.1
D (X)	27	5.5
Total	488	100

4.2.2.3 Estimating Runoff Nutrient Loadings from the Lake Roberts Watershed

A. ESTIMATING RUNOFF VOLUME USING THE NRCS CURVE NUMBER APPROACH

Stormwater runoff from the Lake Roberts watershed was estimated using the NRCS curve number approach. When developing the nutrient PLRG for the Upper Ocklawaha Chain of Lakes, the SJRWMD implemented this approach by setting up a spreadsheet model (Fulton *et al.* 2004). The same model was used to estimate stormwater runoff volume for this analysis, and the governing equations and curve numbers were previously described in the PLRG report (Fulton *et al.* 2004).

Briefly, the key function of the spreadsheet model is to estimate the annual average runoff coefficient for each land use–soil type combination for each year. Once the runoff coefficient is decided, the runoff volume can be calculated as the product of rainfall, runoff coefficient, and acreage of the land use–soil type combination. As discussed earlier, the SJRWMD runoff volume spreadsheet model was based on a 16-land use classification system. Each land use was associated with four soil hydrologic groups (Types A, B, C, and D), giving a total of 64 land use–soil type combinations.

To calculate the runoff volume for the entire Lake Roberts watershed and, at the same time, quantify the runoff contribution from each land use area, the runoff coefficient for each land use–soil type combination needs to be estimated. The SJRWMD runoff model achieved this goal by estimating a watershed-basin average stormwater runoff coefficient ($ASRC_{wb}$) first and then derived the runoff coefficient for the land use–soil type combinations.

The SJRWMD provided the rainfall data used in calculating the runoff coefficient and runoff volume for this TMDL analysis. The SJRWMD Doppler rainfall data were created based on the

measured rainfall from 75 rain gauges located in the SJRWMD area and the Next-Generation Radar (NEXRAD) data that the SJRWMD received from the National Weather Service (NWS).

Based on the SJRWMD Doppler radar rainfall webpage, the individual radar station data are combined into a radar mosaic that completely covers the SJRWMD area with an array of pixels. Each pixel is two square kilometers (km²) in size. The SJRWMD combines the gauge and radar data to calculate a gauge-radar ratio and applies the ratio in a radar calibration algorithm to derive a gauge-adjusted rainfall dataset that maintains the spatial signature of the radar data, while incorporating the volume estimates from the rain gauge.

For this analysis, the set of pixels retrieved for the radar rainfall data was defined by the Lake Roberts watershed boundary. **Table 4.3** summarizes annual rainfall to the Lake Roberts watershed for each year from 2000 through 2012. In this period, annual total rainfall ranged from 25.8 in/yr in 2000 to 59.4 in/yr in 2009, with long-term average annual rainfall of 48.0 in/yr (**Table 4.3**). Dry years were 2000 and 2001, and 2002 and 2009 were wet years.

Inflows from the watershed were classified as a type of tributary inflow (Code 2) in the BATHTUB modeling. This type of inflow requires simulated runoff and nutrient concentrations for each land use type as inputs to the model. Watershed runoff and concentrations associated with any nonpoint source in the watershed were simulated by the NRCS curve number approach and then converted to cubic hectometers per year (hm³/yr) for the BATHTUB modeling.

Annual runoff volume from the Lake Roberts watershed ranged from 267 ac-ft/yr in 2000 to 848 ac-ft/yr in 2009 (**Table 4.4**). The long-term average annual runoff was 582 ac-ft/yr. The pattern of lowest and highest runoff is consistent with the annual rainfall pattern. The second highest runoff volume (778 ac-ft/yr), observed in 2008, may have resulted when Tropical Storm Fay passed through Central Florida in August. This storm produced a large amount of rainfall in a relatively short period, causing the antecedent moisture condition of the soil to elevate and therefore resulting in a higher runoff volume in 2008.

Different land use areas contributed different amount of runoff in the Lake Roberts watershed. Of the long-term annual total runoff of 582 ac-ft/yr, 141 ac-ft/yr were from urban land areas, including low- and medium-density residential areas and low- and high-density commercial. The runoff from these urban areas accounted for 24 % of the total runoff volume from the entire watershed. The land use contributing the greatest runoff volume was medium-density residential, which alone contributed 115 ac-ft/yr, accounting for 20 % of total watershed runoff and 77 % of total runoff from urban areas. Natural land uses, including upland forest/rangeland, waters, and wetlands, contributed 423 ac-ft/yr, accounting for 73 % of total watershed runoff. The runoff contribution from rural areas, including pasture, cropland, and other agricultural land, plus some runoff from open and recreational areas, was relatively low. The total runoff volume from these areas was 17.2 ac-ft/yr, accounting for 3 % of total watershed runoff.

Table 4.3. Annual rainfall to the Lake Roberts watershed

Year	Annual Rainfall (in)
2000	25.8
2001	38.9
2002	59.9
2003	47.1
2004	56.4
2005	57.1
2006	43.4
2007	43.8
2008	56.2
2009	59.4
2010	48.0
2011	40.1
2012	48.5
Mean	48.0

Table 4.4. Runoff volume (ac-ft/yr) from the Lake Roberts watershed

Year	Low-Density Residential	Medium-Density Residential	Low-Density Commercial	High-Density Commercial	Open Land/Recreational	Pasture	Tree Crops	Other Agriculture	Forest/Rangeland	Water	Wetlands	Total Runoff Volume
2000	10.8	31.7	0.8	0.3	1.8	0.6	0.3	0.0	0.3	45.6	175.3	267.5
2001	17.8	49.0	1.2	0.5	3.7	1.3	0.5	0.0	0.6	68.7	264.7	408.1
2002	39.7	86.2	1.9	0.8	14.1	5.5	1.9	0.0	2.0	106.8	414.2	673.1
2003	25.5	62.8	1.5	0.6	7.1	2.7	1.0	0.0	1.1	83.6	323.0	508.9
2004	47.5	90.0	1.8	0.8	20.2	8.0	2.8	0.0	2.9	101.4	395.2	670.5
2005	35.3	79.9	1.8	0.8	11.7	4.5	1.6	0.0	1.7	101.6	393.2	632.1
2006	12.8	126.5	2.9	0.6	5.6	4.7	1.6	0.0	1.6	110.9	268.6	535.9
2007	9.3	114.1	2.9	0.6	3.2	2.5	0.9	0.0	0.9	110.7	267.0	512.2
2008	27.5	203.8	4.1	0.8	14.7	12.7	4.3	0.0	4.3	146.6	358.9	777.7
2009	32.5	227.9	4.4	0.9	17.8	15.6	5.3	0.0	5.3	155.8	382.8	848.2
2010	14.6	141.3	3.3	0.7	6.4	5.4	1.9	0.0	1.9	122.7	297.4	595.6
2011	18.3	140.6	2.9	0.6	9.6	8.3	2.8	0.0	2.8	104.3	254.9	545.1
2012	12.8	135.7	3.3	0.7	5.2	4.3	1.5	0.0	1.5	123.4	298.4	586.9
Mean	23.4	114.6	2.5	0.7	9.3	5.9	2.0	0.0	2.1	106.3	314.9	581.7

B. ESTIMATING RUNOFF NUTRIENT LOADS FROM THE LAKE ROBERTS WATERSHED

Runoff nutrient loads were calculated as the sum of nutrient loads from areas occupied by different land use types. The loads from each land use type were calculated by multiplying the runoff volume from each land use by runoff TN and TP concentrations specific to that land use type. These runoff nutrient concentrations are commonly referred to as event mean concentrations (EMCs). EMCs are determined through stormwater studies, in which both runoff volume and runoff nutrient concentrations are measured at a series of phases from a given stormwater event. The EMC for the stormwater event is then calculated as the mean concentration weighted for the runoff volume.

The TN and TP EMCs (**Table 4.5**) used in developing these TMDLs were used by the SJRWMD in the nutrient PLRG for the Upper Ocklawaha Chain of Lakes (Fulton et al. 2004). Based on the SJRWMD PLRG report, these EMCs were primarily cited from Dr. H. Harper's 1994 stormwater review report (Harper 1994). Several other published reports in the literature—including Goldstein and Ulevich 1981, Izuno et al. 1991, Fonyo et al. 1991, and Hendrickson and Konwinski 1998—were also analyzed to supplement the numbers in the Harper (1994) report. Orange County provided measured ambient TN and TP data for wetlands that are considered a site-specific EMC value. Therefore, the wetland EMCs of 0.113 mg/L for TP and 1.55 mg/L for TN were used in the development of these TMDLs.

Table 4.5. EMCs of TN and TP for different land use types

Land Use	TP EMC (mg/L)	TN EMC (mg/L)
Low-density residential	0.177	1.77
Medium-density residential	0.3	2.29
High-density residential	0.49	2.42
Low-density commercial	0.195	1.22
High-density commercial	0.43	2.83
Industrial	0.339	1.98
Mining	0.15	1.18
Pasture	0.387	2.48
Tree crops	0.14	2.05
Cropland	0.666	4.56
Other agriculture	0.492	2.83
Feeding operations	6.532	78.23
Open land/recreational	0.057	1.25
Forest/rangeland	0.057	1.25
Wetlands	0.113	1.55
Water	0.013	0.49

Nutrient removal by stormwater treatment facilities in urban areas was also considered in simulating watershed nutrient loads. It was assumed that all urban construction after 1984, when Florida implemented the Stormwater Rule, had stormwater treatment facilities that removed TN and TP loads at certain removal efficiencies. To identify the construction taking place after 1984, watershed land use distribution data from 2004 and 2009 were compared with the 1988 land use distribution GIS shapefile, which was the earliest land use GIS shapefile available in the DEP GIS dataminer. It was assumed that urban land use areas in the 1988 land use shapefile did not have any stormwater treatment facilities required by the state Stormwater Rule. This assumption should be close to reality because the 1988 land use shapefile was created based on 1987 land use aerial photography.

Compared with the periods from 1984 to 2004 and 1984 to 2009, the chance of missing some urban construction between 1984 and 1987 was relatively small, and therefore should not cause a significant error in simulating nutrient loads. Any urban land areas that were not in the 1988 land use shapefile but appeared in the 2004 or 2009 land use shapefiles were considered new construction with stormwater treatment facilities. When calculating watershed nutrient loads, nutrient loads created from these urban areas are subject to stormwater treatment and TN and TP removal at a certain percentage. Based on studies of 13 stormwater treatment systems, it was assumed that these facilities removed 63 % of the phosphorus load and 42 % of the nitrogen load (Fulton et al. 2004).

Another aspect of the nutrient load simulation was the effective delivery of nutrients to the receiving water after going through the overland transport process. In this analysis, all dissolved components of TN and TP were considered to be reaching the receiving water without any loss. Particulate fractions of TN and TP were considered subject to loss through overland transport. Therefore, the amount of nutrients that eventually reaches the receiving water consists of two parts: the unattenuated dissolved fraction (T) and the particulate fraction attenuated through the overland transport process. The portion of nutrients eventually reaching the receiving water is represented using Equation 1, which is a function established in the Reckhow et al. (1980) analyses.

$$D = (1 - T) * e^{(1.01 - 0.34 * \ln(L))} + T \quad \text{Equation 1}$$

Where,

D is the portion of the nutrients eventually reaching the receiving water.

T is the dissolved fraction of total nutrient (TN and TP) concentrations.

$(1-T)$ is the particulate fraction of the total nutrient (TN and TP) concentrations.

The exponential item of the equation represents the delivery ratio of the particulate nutrients.

L is the length of the overland flow path.

The percent dissolved TN and TP concentrations for different land uses used were cited from the SJRWMD Upper Ocklawaha Chain of Lakes PLRG report (Fulton et al. 2004). These numbers were created by comparing concentrations of TN, TP, orthophosphate (PO_4), total dissolved phosphorus (TDP), and total dissolved nitrogen (TDN) from several studies on stormwater runoff conducted in Florida (Hendrickson 1987; Fall and Hendrickson 1988; German 1989; Fall 1990; Dierberg 1991; Izuno et al. 1991; and Harper and Miracle 1993). **Table 4.6** shows the percent concentration of dissolved phosphorus and nitrogen for different land uses.

Table 4.6. Dissolved fraction of TN and TP concentrations for different land uses

Land Use	% Dissolved Phosphorus	% Dissolved Nitrogen
Low-density residential	50.1	75.3
Medium-density residential	50.1	75.3
High-density residential	50.1	75.3
Low-density commercial	41.4	65.7
High-density commercial	76.7	76.7
Industrial	76.1	76.1
Mining	46.7	65.7
Pasture	72.2	90.8
Tree crops	62.9	90.8
Cropland	60.0	90.8
Other agriculture	68.7	90.8
Feeding operations	58.3	90.8
Open land/recreational	50.1	75.3
Forest/rangeland	50.1	75.3
Wetlands	50.7	77.5
Water	11.8	41.3

The length of the overland flow path can be estimated by defining the location of the centroid of the watershed using the ArcGIS Spatial Analyst applications. Then the distance between the centroid and the boundary of the lake is considered the length of the overland flow path. However, this approach works best for watersheds divided into multiple subwatersheds. It underestimates the length of the flow path if the entire watershed is treated as the only entity that discharges into a lake, especially if the lake is located close to the center of the watershed—in which case the centroid of the watershed is located in the lake and the length of the overland flow path is considered zero.

Therefore, for these TMDLs, since no subwatershed is delineated, the length of the overland flow path was estimated by randomly picking 20 transects and measuring the distance between the boundary of the watershed and the boundary of the lake. The final length of the overland flow path was calculated as the mean value of the lengths of these 20 transect measurements. For

the Lake Roberts watershed, the average length of the overland flow path was estimated to be 525 meters.

Tables 4.7 and **4.8** list the stormwater runoff TN and TP loads from the Lake Roberts watershed estimated using the procedures described above. The annual runoff TP loads reaching Lake Roberts ranged from 27 to 106 kilograms per year (kg/yr) from 2000 to 2012 (**Table 4.7**). The long-term average annual TP runoff loads for the period were 66 kg/yr. The lowest and highest runoff TP loads were observed in 2000 and 2009, respectively, which is consistent with the pattern of annual runoff volume (**Table 4.4**).

Different land use areas contributed different amounts of runoff TP loads in the watershed. Of the long-term annual total runoff TP loads (66 kg/yr), 32.8 kg/yr were from urban areas, including low- and medium-density residential areas, and low- and high-density commercial areas. These loads accounted for 49.6 % of total runoff TP loads from the entire watershed (**Figure 4.4**). The anthropogenic land use area contributing the highest runoff TP loads to the lake was medium-density residential, which alone contributed 28.5 kg/yr, accounting for 44 % of total runoff TP loads from the watershed and 87 % of total runoff TP loads from urban areas.

Natural land areas, including upland forest/rangeland, waters, and wetlands, contributed 30 kg/yr, accounting for 46 % of total runoff TP loads. Runoff TP loads contributed by rural areas, including pasture, cropland, and other agricultural land, plus some runoff from open and recreational areas, were 3.2 kg/yr, accounting for 4.8 % of total watershed runoff TP loads. Thus, among human land uses, urban areas are a major runoff TP contributor in the Lake Roberts watershed.

The runoff TN annual loads in the period from 2000 to 2012 ranged from 403 kg/yr in 2000 to 1,370 kg/yr in 2009. The inter-annual pattern is similar to that of runoff TP loads. The long-term average annual runoff TN loads from the entire watershed were 911 kg/yr. The majority of these TN loads were created in wetlands and medium-density residential areas, which contributed 512 and 274 kg/yr to the lake, respectively. The total anthropogenic TN loading to the lake is 359 kg/yr, accounting for 39 % of total TN loading (**Figure 4.5**). Among anthropogenic land uses, medium-density residential is a major TN contributor to the lake, accounting for 77 % of total anthropogenic TN loading (**Figure 4.5**). Agricultural areas contributed 23 kg/yr, accounting for 2.4 % of total watershed runoff TN loads. Natural land areas contributed 552 kg/yr of runoff TN, accounting for 61 % of total runoff TN loads.

Table 4.7. Runoff TP annual loads (kg/yr) from the Lake Roberts watershed

Year	Low-Density Residential	Medium-Density Residential	Low-Density Commercial	High-Density Commercial	Open Land/Recreational	Pasture	Tree Crops	Other Agriculture	Forest/Rangeland	Water	Wetlands	Total Runoff Load
2000	1.57	7.8	0.12	0.15	0.08	0.24	0.03	0.00	0.01	0.29	16.3	26.6
2001	2.78	12.3	0.18	0.23	0.21	0.66	0.08	0.00	0.03	0.44	24.7	41.6
2002	6.67	22.5	0.28	0.37	0.85	2.81	0.33	0.00	0.12	0.69	38.8	73.5
2003	3.69	15.4	0.22	0.28	0.33	1.05	0.13	0.00	0.05	0.54	30.1	51.8
2004	6.95	22.2	0.27	0.35	0.95	3.15	0.36	0.00	0.14	0.65	36.8	71.8
2005	5.33	19.9	0.26	0.35	0.59	1.91	0.23	0.00	0.09	0.65	36.7	66.0
2006	1.88	31.2	0.43	0.27	0.26	1.86	0.22	0.00	0.08	0.71	25.0	61.9
2007	1.34	28.0	0.42	0.26	0.15	0.97	0.12	0.00	0.04	0.71	24.8	56.9
2008	4.13	50.9	0.60	0.36	0.71	5.17	0.59	0.00	0.21	0.95	33.5	97.1
2009	4.73	56.1	0.64	0.39	0.83	6.06	0.68	0.00	0.24	1.00	35.6	106.3
2010	2.13	34.8	0.48	0.29	0.30	2.13	0.25	0.00	0.09	0.79	27.7	69.0
2011	2.66	34.5	0.42	0.26	0.44	3.21	0.37	0.00	0.13	0.67	23.7	66.4
2012	2.17	35.3	0.48	0.30	0.31	2.20	0.25	0.00	0.09	0.80	28.0	69.9
Mean	3.54	28.5	0.37	0.30	0.46	2.42	0.28	0.00	0.10	0.69	29.4	66.1

Table 4.8. Runoff TN annual loads (kg/yr) from the Lake Roberts watershed

Year	Low-Density Residential	Medium-Density Residential	Low-Density Commercial	High-Density Commercial	Open Land/Recreational	Pasture	Tree Crops	Other Agriculture	Forest/Rangeland	Water	Wetlands	Total Runoff Load
2000	19.7	74.6	0.9	1.0	2.3	1.8	0.6	0.0	0.4	16.7	284.4	402.5
2001	34.8	118.2	1.4	1.5	5.9	4.9	1.5	0.0	0.9	25.3	430.6	625.1
2002	83.8	215.9	2.2	2.4	23.6	20.8	6.0	0.0	3.4	39.4	677.3	1,074.9
2003	46.3	147.9	1.7	1.9	9.1	7.7	2.3	0.0	1.4	30.7	524.0	773.1
2004	87.3	212.7	2.1	2.3	26.3	23.3	6.7	0.0	3.8	37.3	641.5	1,043.3
2005	66.9	191.2	2.1	2.3	16.3	14.2	4.2	0.0	2.4	25.1	639.2	963.7
2006	23.6	299.1	3.4	1.7	7.3	13.7	4.0	0.0	2.2	40.7	436.0	831.8
2007	16.9	268.7	3.3	1.7	4.1	7.2	2.2	0.0	1.2	40.7	433.2	779.1
2008	51.9	488.1	4.7	2.4	19.7	38.3	10.7	0.0	5.8	53.9	583.9	1,259.5
2009	59.4	537.4	5.1	2.5	23.0	44.8	12.5	0.0	6.8	57.2	621.2	1,369.9
2010	26.7	333.7	3.8	1.9	8.4	15.8	4.5	0.0	2.5	45.1	482.8	925.2
2011	33.3	331.1	3.3	1.7	12.3	23.8	6.7	0.0	3.6	38.3	413.6	867.7
2012	27.3	338.5	3.8	2.0	8.6	16.2	4.7	0.0	2.5	30.6	487.8	922.0
Mean	44.5	273.6	2.9	2.0	12.8	17.9	5.1	0.0	2.8	37.0	512.0	910.6

Percent TP loads (%)
(Average TP Load = 66 kg/yr)

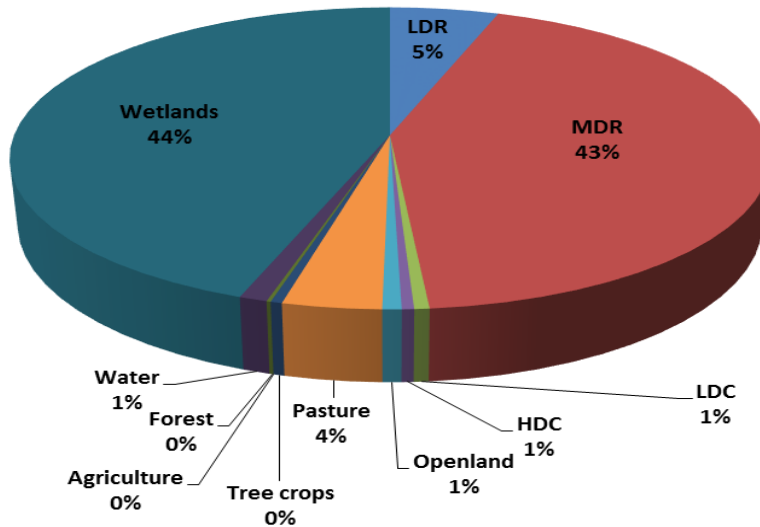

Figure 4.4. Percent TP runoff loads from different land uses in the Lake Roberts watershed. LDR and MDR represent low- and high-density residential, and LDC and HDC indicate low- and high-density commercial, respectively.

Percent TN loads (%)
(Average TN Load = 911 kg/yr)

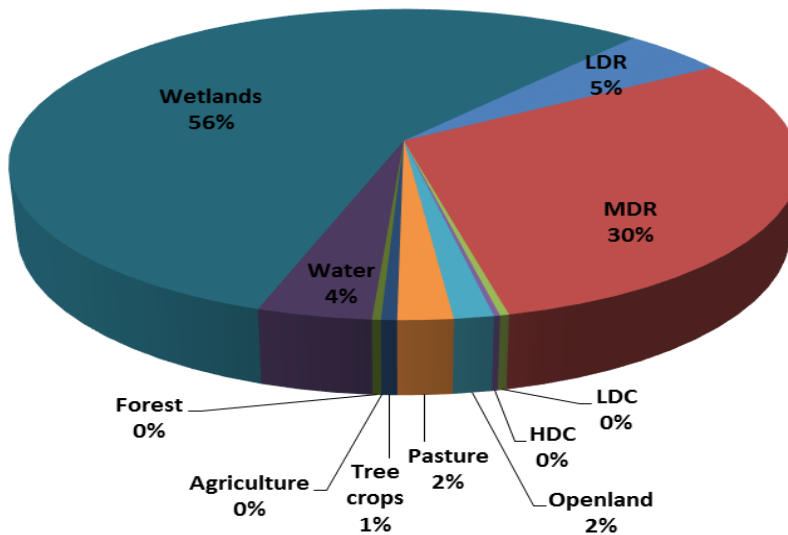

Figure 4.5. Percent TN runoff loads from different land uses in the Lake Roberts watershed. LDR and MDR represent low- and high-density residential, and LDC and HDC indicate low- and high-density commercial, respectively.

4.2.2.4 Estimating Septic Tank Nutrient Loadings from the Lake Roberts Watershed

Septic tanks are an important source of nutrients for many eutrophic lakes. Failed septic tanks contribute nutrient loads primarily through surface runoff, which was implicitly considered when simulating the runoff nutrient loads using EMCs for different land use types. However, even normally functioning septic tanks can contribute nutrients through groundwater. This is because septic tanks use soil as a major mechanism to remove nutrients. The nutrient removal can happen due to uptake by vegetation and adsorption by soil particles in the drain field. But neither process can remove 100 % of the nutrients. A portion of the nutrients always enters groundwater, and through that pathway enters the impaired surface water. For these TMDLs, septic tank phosphorus loads and nitrogen loads were estimated using different methods, and these loading estimates were used to better calculate anthropogenic inputs from ground seepage nutrient loadings in **Chapter 5**.

A. ESTIMATING PHOSPHORUS LOADS FROM SEPTIC TANKS

Phosphorus compounds from septic tanks are either organic or inorganic. Compared with nitrogen compounds, soil can remove phosphorus compounds relatively easily because the molecules of organic phosphorus compounds are large and inorganic phosphorus compounds contain a high electrical charge. These characteristics are responsible for the high removal rate of phosphorus in soil. It is generally accepted that within 200 meters, 90 % of the phosphorus loads from septic tanks can be removed through plant uptake and soil removal (Fulton 1995). For these TMDLs, the septic tank phosphorus loads (L_{ST}) were estimated using **Equation 2**:

$$L_{ST} = (L_{Cap} * CY) * (1 - SR) \quad \text{Equation 2}$$

Where,

L_{Cap} is the phosphorus load to septic systems per capita-year.

CY is the number of capita-years in the watershed serviced by septic systems impacting the lake.

SR is the soil retention coefficient. Here, $SR = 0.9$.

The per capita-year phosphorus load was cited from the SJRWMD's first version of the nutrient PLRG for the Upper Ocklawaha Chain of Lakes, or 1.48 kg/capita/yr. This number came from a septic tank review analysis conducted by Reckhow et al. (1980), based on 8 septic tank studies.

To obtain the CY value, the number of families in the Lake Roberts watershed on septic tanks within 200 meters of the lake was determined. It was assumed that each family was serviced with one septic tank. Therefore, the number of families serviced with septic tanks was considered equal to the number of septic tanks.

The number of septic tanks in the Lake Roberts watershed was obtained from a septic tank GIS shapefile in DEP's GIS dataminer. This shapefile, created by the Florida Department of Health (FDOH) in July 2011, includes the septic tanks inspected by FDOH. A subset of septic tanks located in the Lake Roberts watershed was selected using the Selection by Location tool of ArcGIS 10.1. The selected septic tanks were exported as a separate shapefile that included only the septic tanks in the watershed. A shapefile of a 200-meter septic tank impact zone around Lake Roberts was then created using the ArcGIS Buffer tool. The impact zone shapefile was used to identify septic tanks located within 200 meters of Lake Roberts. Based on this analysis, there are 63 treatment systems within 200 meters of Lake Roberts.

When these TMDLs were developed, no information was obtained on the number of people living in households with septic tanks located within 200 meters of Lake Roberts. Therefore, the average household size of Orange County was used as the surrogate for these households. Based on the [2010 data published by the U.S. Census Bureau](#), the total population in Orange County Census Tract 171.04 was 22,670 individuals. There were 7,357 occupied households. Based on these numbers, there was an average of 2.76 people in each household. This TMDL analysis assumes that both households comprise long-term Orange County residents. Using **Equation 2**, the septic tank phosphorus load contribution to Lake Roberts is 25.7 kg/yr:

$$L_{ST} = 1.48 \text{ kg/capita/yr} \times 2.76 \text{ people/household} \times 63 \text{ household} \times (1-0.9) = 25.7 \text{ kg/yr}$$

B. ESTIMATING NITROGEN LOADS FROM SEPTIC TANKS

Septic tank loads from nitrogen are not as easily removed by soil as phosphorus, mostly because septic tank effluent is mainly composed of ammonia, which, under the aerobic conditions of a drain field, is oxidized to nitrate/nitrite through nitrification. Nitrate/nitrite is very soluble and can percolate into groundwater with septic tank effluent or rainfall infiltration. In addition, nitrate/nitrite has monovalent bond molecules with a very weak soil binding capacity. The only way that they can be removed, other than by vegetation uptake, is through denitrification, an anaerobic process in which bacteria convert nitrate to nitrogen gas. Nitrate-nitrogen is removed when nitrogen gas leaves the soil solution. Depending on soil conductivity, porosity, the topography of the land surface, the flow rate of groundwater, and soil organic content, different amounts of nitrate/nitrite-nitrogen coming from septic tanks can be removed before they reach the impaired receiving waterbody.

For TMDL development, the septic tank nitrogen loading to Lake Roberts was simulated using a grid-based GIS model called [ArcNLET](#), developed by the Florida State University Department of Scientific Computing. The model simulates the transport of nitrogen in groundwater and the nitrogen loads that eventually reach the receiving water by considering nitrogen advection, hydrodynamic dispersion, and denitrification in the soil. The model also considers the spatial heterogeneity of the land surface topography, soil conductivity and porosity, and the location of

septic tanks corresponding to the receiving waterbody. A major advantage of the model is that it can be used to estimate the loading impact of each individual septic tank in the watershed on the final nitrogen loads reaching the receiving water. Major variables simulated by ArcNLET include groundwater seepage velocity, nitrogen concentration at any location in the concentration plume, and the nitrogen loading that eventually reaches the receiving waterbody.

Ye and Zhu (2014) conducted a study for DEP to estimate nitrogen loads from septic systems to Lake Roberts and three other lakes in the Ocklawaha River Basin. The study cited in **Appendix D** (Ye et al. 2014) provides details of the ArcNLET modeling. The mukey-specific hydraulic conductivity and porosity were then linked to the SSURGO shapefile to create the spatial distribution of soil hydraulic conductivity and porosity for the Lake Roberts watershed. The Feature to Raster converting tool of ArcGIS 10.1 was used to create raster files for hydraulic conductivity and porosity for the watershed. The GIS shapefile that identifies septic tank locations in the watershed used for simulating septic tank nitrogen loads was the same as the septic tank point shapefile used to quantify septic tank phosphorus loads. This shapefile was retrieved from DEP's GIS dataminer and created based on FDOH septic tank survey results.

A subset of septic tanks located in the watershed was selected using the Selection by Location tool of ArcGIS 10.1 and the boundary shapefile for the Lake Roberts watershed. The shapefile showing the locations of waterbodies in the watershed was created using the waterbody and swamp and marsh shapefiles in the USGS 1:24,000 National Hydrography Dataset (NHD) coverage in DEP's GIS dataminer. Depending on the septic tank locations, topography, and distance between septic tanks and receiving waters, plumes may enter lakes, ponds, and wetlands other than Lake Roberts. The Ye and Zhu (2014) analysis estimated that septic tank nitrogen loads to Lake Roberts were 331 kg/yr with the calibrated smoothing factor.

Chapter 5: Determination of Assimilative Capacity

5.1 Determination of Loading Capacity

Nutrient enrichment and the resulting problems related to eutrophication tend to be widespread and are frequently manifested far (in both time and space) from their sources. Addressing eutrophication involves relating water quality and biological effects such as photosynthesis, decomposition, and nutrient recycling as acted on by environmental factors (i.e., rainfall, point source discharge, etc.) to the timing and magnitude of constituent loads supplied from various categories of pollution sources. Assimilative capacity should be related to some specific hydrometeorological condition during a selected time span or to some range of expected variation in these conditions.

The goal of this analysis is to identify the maximum allowable TN and TP loadings from the watershed, so that Lake Roberts will meet the TMDL targets and thus maintain its function and designated use as a Class III water. To achieve the goal, DEP selected BATHTUB as the waterbody model and ran it through the 13-year period of observation to simulate *Chla* responses in the lake to watershed nutrient loadings and ultimately to estimate assimilative capacity.

5.2 Water Quality Trends for Lake Roberts

Water quality data for Lake Roberts were retrieved from IWR Run 49. Only 1 water quality station in the lake was identified for the period of observation (**Table 5.1; Figure 5.1**). **Figure 5.2** shows temporal trends of *Chla*, TN, and TP concentrations and TN/TP ratios. A long-term average of TN was 1.17 ± 0.25 mg/L ($n = 38$) during the planning and verified periods from 2000 through 2012, with a coefficient of variance (CV) of 22 % (**Table 5.2**). Similarly, TP concentrations averaged 0.044 ± 0.017 mg/L ($n = 39$), with a CV of 39 %. Although increased concentrations of TP were measured between 2000 and 2005, the CV of TN and TP indicated that in-lake concentrations of TN and TP remained relatively constant over the 13-year period of observation.

Table 5.1. Water quality station in Lake Roberts over the period of record, 1994–2013

Waterbody	Station	Latitude	Longitude	Number of Observations	Beginning Date	Ending Date
2872A	21FLORANA33	28.51779	-81.57080	2,320	1994	2013

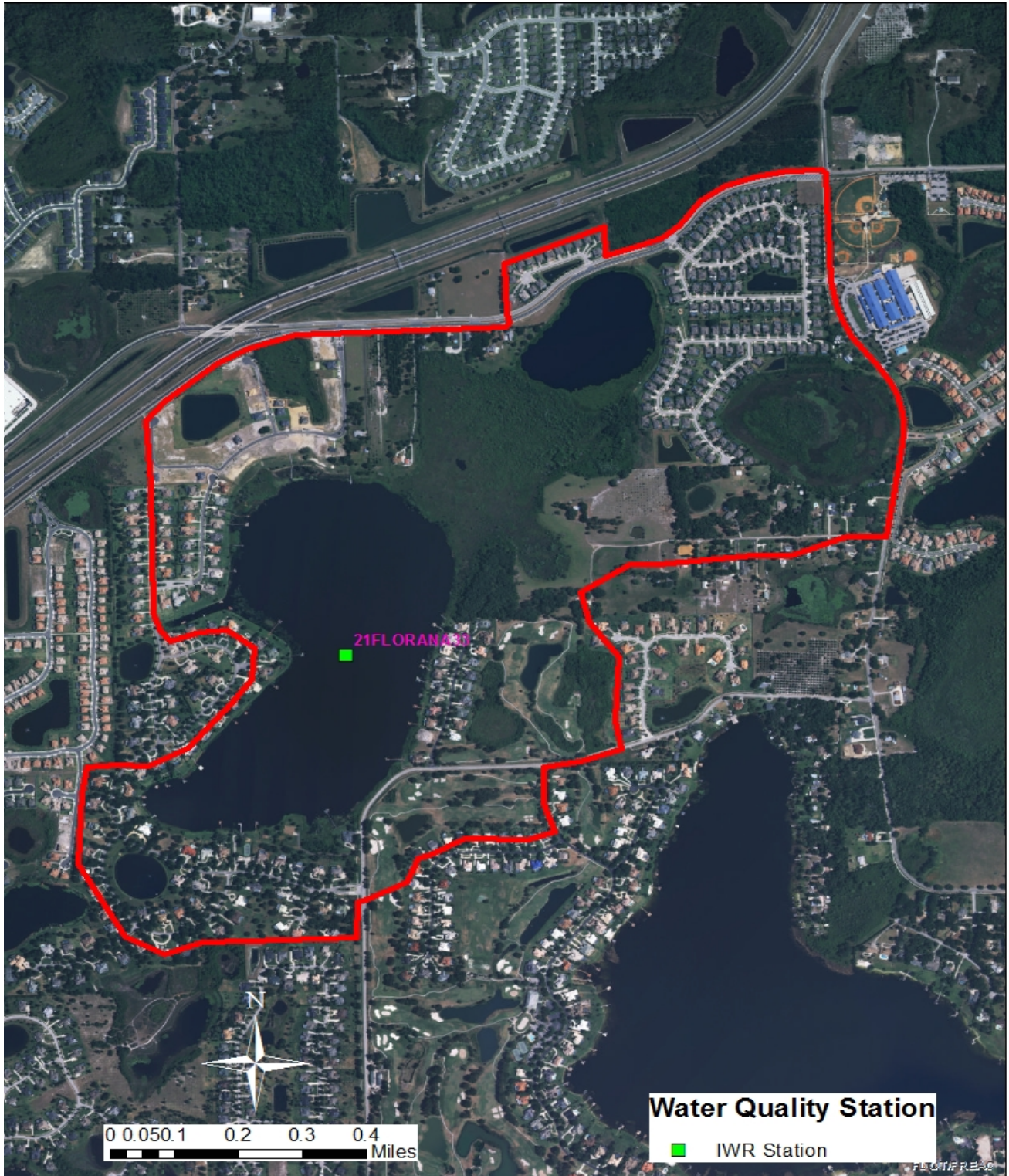

Figure 5.1. Location of water quality station in Lake Roberts

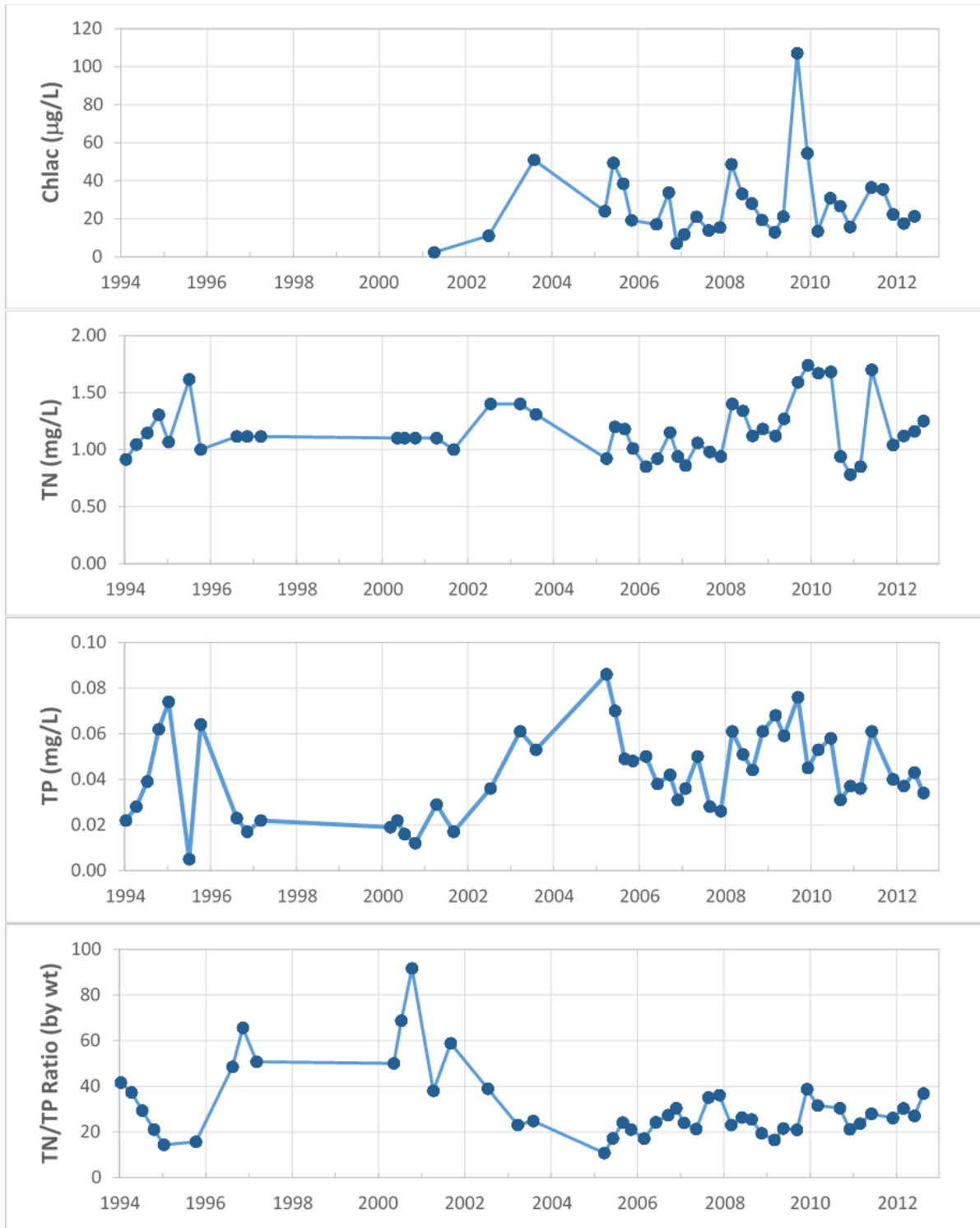

Figure 5.2. Long-term trend concentrations of Chl a, TN, and TP and TN/TP ratios in Lake Roberts, 1994–2012

Table 5.2. Summary of statistics of water quality parameters in Lake Roberts observed during the assessment (planning and verified) period, 2000–12

Water Quality Variables	Unit	No. of Obs.	Median	Mean	Standard Deviation	Minimum	Maximum	CV (%)
Chl _a	µg/L	31	21.3	27.7	19.9	2.4	107	72
TN	mg/L	38	1.12	1.17	0.25	0.780	1.740	22
TP	mg/L	39	0.043	0.044	0.017	0.012	0.086	39
Dissolved Oxygen (DO)	mg/L	39	7.50	7.74	1.43	5.0	11.3	19
Total Suspended Solids	mg/L	37	4.0	4.6	2.7	1.0	11.0	60
Color	PCU	39	60	67	30.7	21	160	46
Secchi Depth	meters (m)	40	1.0	1.0	0.3	0.5	1.6	28
Alkalinity	CaCO ₃	38	36	35	9.3	16.3	56	27
TN/TP Ratio	No unit	38	26.1	30.4	15.2	10.7	91.7	50

As a result, the TN/TP ratios (n = 33) were found to be relatively constant over the period except for the dry years in 2000 and 2001, with an average of 26 ± 6.6 and a CV of 26 %. The TN/TP ratio indicated that the lake may have been co-limited during the period of observation.

Concentrations of annual Chl_a in Lake Roberts ranged from 2.4 µg/L in 2000 to 107 µg/L in 2009, with an average of 27.7 ± 19.9 µg/L (n = 31) and a CV of 72 % (Table 5.2). The peak concentration of annual Chl_a in 2009 may be associated with the elevated concentrations of annual TN and TP observed in 2009 (Table 5.3).

Table 5.3. Annual means and standard deviation (± 1 sigma standard deviation) of Chl_a, TN, and TP and TN/TP ratios in Lake Roberts, 2000–12

STD = 1-sigma standard deviation; NA = Not available

Year	Chl <i>a</i> (µg/L)	Chl <i>a</i> STD	TN (mg/L)	TN STD	TP (mg/L)	TP STD	TN/TP Ratio (no unit)	TN/TP Ratio STD
2000	NA	NA	1.100	0.000	0.017	0.004	70.1	20.9
2001	2.40	NA	1.050	0.071	0.023	0.008	48.4	14.8
2002	11.10	NA	1.400	NA	0.036	NA	38.9	NA
2003	50.90	NA	1.355	0.064	0.057	0.006	23.8	1.2
2004	NA	NA	NA	NA	NA	NA	NA	NA
2005	32.70	13.76	1.078	0.135	0.063	0.018	18.2	5.8
2006	19.30	13.53	0.965	0.129	0.040	0.008	24.7	5.7
2007	15.48	3.98	0.960	0.083	0.035	0.011	29.1	7.6
2008	32.28	12.34	1.260	0.132	0.054	0.008	23.5	3.1
2009	48.88	42.76	1.430	0.285	0.062	0.013	24.4	9.8
2010	21.63	8.40	1.268	0.475	0.045	0.013	28.0	4.7
2011	31.40	7.89	1.197	0.446	0.046	0.013	25.8	2.1
2012	19.40	2.69	1.177	0.067	0.038	0.005	31.3	5.0

Table 5.3 summarizes the annual mean concentrations of Chl a , TN, and TP, and TN/TP ratios observed between 2000 and 2012. No water quality data were available for 2004. Annual concentrations of TN and TP ranged from 0.96 mg/L in 2007 to 1.43 mg/L in 2009, and from 0.017 mg/L in 2000 to 0.062 mg/L in 2009, respectively. The peak concentrations of TN and TP in 2009 occurred when rainfall was highest among the 13 years of observation, suggesting that watershed runoff may play an important role in delivering TN and TP to the lake. Annual Chl a concentrations ranged from 2.4 μ g/L in 2000 to 50.9 μ g/L in 2003, and were elevated in 2003 and 2009.

Figure 5.3 shows monthly TN, TP, and Chl a concentrations observed for Lake Roberts from 2000 through 2012. As expected, no seasonal trends were observed for TN and TP concentrations or TN/TP ratios during the 13-year period. However, monthly Chl a concentrations were slightly elevated in May through September compared with December through April, showing a peak concentration in September. This seasonal trend seems typical in subtropical regions, indicating that algae production is greater from May through November. The average concentration of Chl a during the growing season was 29.4 μ g/L, while the concentration during the nongrowing season averaged 16.7 μ g/L, a difference of 12.7 μ g/L.

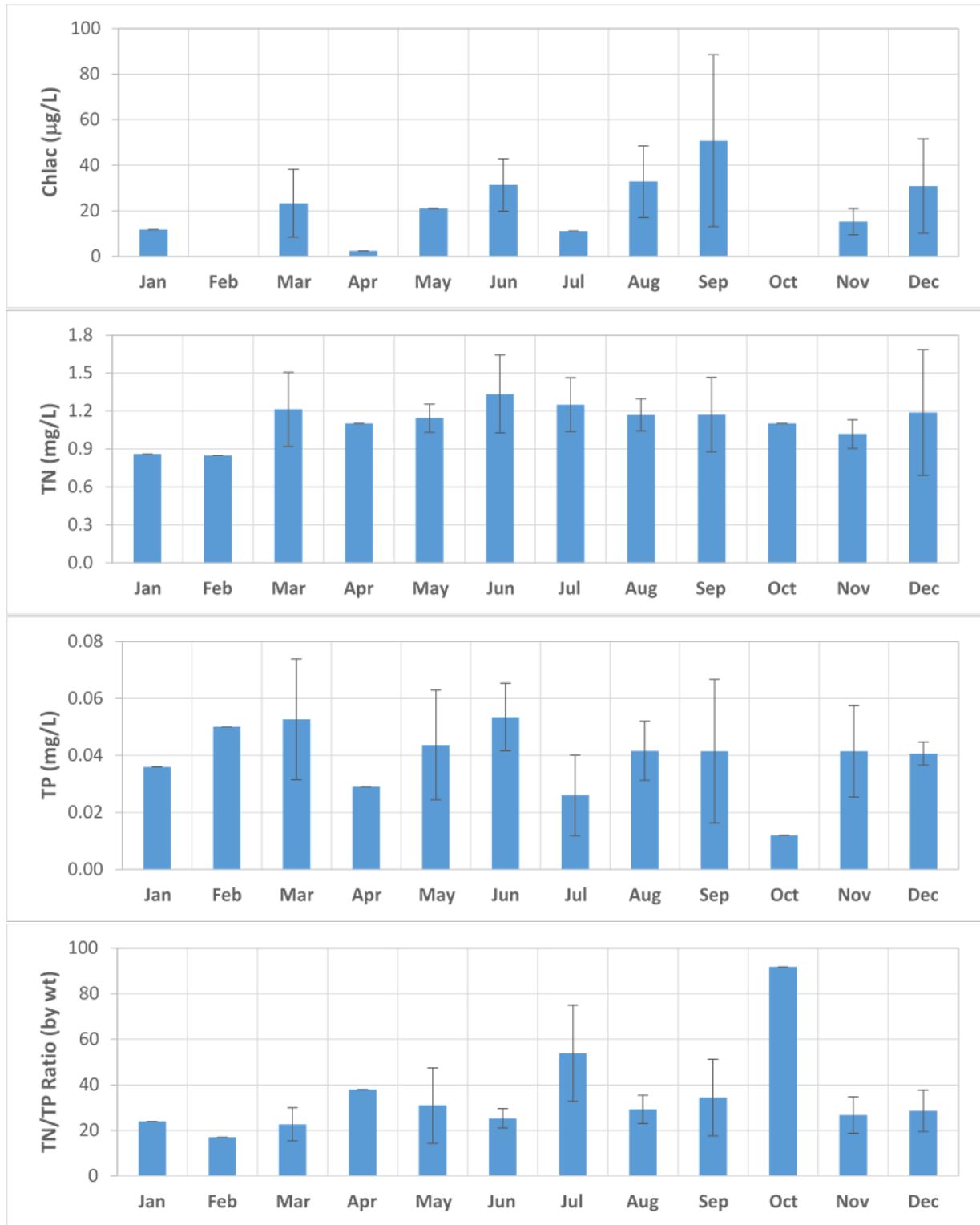

Figure 5.3. Monthly variations of Chl a, TN, and TP and TN/TP ratios in Lake Roberts, 2000–12. Error bars represent a 1-sigma standard deviation.

5.3 Lake Roberts Water Quality Modeling

5.3.1 BATHTUB Overview

The U.S. Army Corps of Engineers (USACOE) BATHTUB model was used to assess in-lake water quality responses to watershed TN and TP loads. BATHTUB is a series of empirical nutrient and eutrophication models for lakes and reservoirs. The model performs steady-state water and nutrient balance calculations in a spatially segmented hydraulic network, which accounts for advective and diffusive transport, and nutrient sedimentation (Walker 1999). BATHTUB is often used to simulate the fate and transport of nutrients, water quality conditions, and responses to nutrient loading in a lake or similar waterbody.

BATHTUB is composed of three major components: water balance, nutrient sedimentation, and eutrophication response models, expressed in terms of TN, TP, Chl a , transparency, organic nitrogen (N), and organic phosphorus (P). To simulate water quality conditions, BATHTUB requires information on various lake characteristics such as length, width, mean depth, and nutrient loads from sources in the surrounding watershed. These data are then used to evaluate key in-lake water quality parameters such as nutrient concentrations, turbidity, and algae growth. One major advantage of BATHTUB over other lake models is its use of simple steady-state calculations to address eutrophication processes, reducing data demands. Particularly where data are limited, BATHTUB has been cited as an effective tool for lake and reservoir water quality assessment and management.

The net accumulation of nutrients in a lake is a result of nutrient mass balance between incoming flow to the lake and outgoing flow from the lake and the decay of nutrients in the lake. BATHTUB provides several submodels, depending on the inorganic/organic nutrient partitioning coefficient and reaction kinetics. The major pathway for removing TN and TP from the water column, in these simplified empirical equations, is through sedimentation to the bottom of the lake. The prediction of Chl a concentrations by BATHTUB also involves choosing one of several alternative models, depending on whether algal communities are limited by phosphorus or nitrogen, or co-limited by both nutrients. Scenarios that include algal communities limited by light intensity or controlled by lake flushing rate are also included in the suite of models. The variety of models available in BATHTUB allows the user to choose specific models based on the particular condition of a lake.

The nutrient balance model adopted by BATHTUB assumes that the net accumulation of nutrients in a lake is the difference between nutrient loadings into the lake from various sources and the nutrients carried out through outflow and the losses of nutrients through whatever decay processes occur inside the lake. In this analysis, nutrient inputs included TN and TP loadings through stormwater surface runoff from various land uses, baseflow contribution (including contributions from septic tanks), artesian input, and atmospheric precipitation. Nutrient output was considered primarily through lake outflow. To address nutrient decay in the lake,

BATHTUB provides several alternatives, depending on the inorganic/organic nutrient partitioning coefficient and reaction kinetics. Since the major pathway of decay for TN and TP in the model is through sedimentation to the bottom of the lake, the actual sedimentation rate is the net difference between the gross sedimentation rate and sediment resuspension rate.

5.3.2 BATHTUB Inputs

5.3.2.1 Morphologic Characteristics of Lake Roberts

DEP conducted a bathymetric survey for Lake Roberts in August 2013. The survey was performed using a Hummingbird Wide-100 fathometer attached to a boat that took depth readings from designated points along lake transects. Depth readings and satellite-based positioning information determined using a global positioning system (GPS) (Trimble GeoXT GPS unit) were used to develop bathymetric contour maps and morphologic characteristics for the lake. To ensure that correct depth readings were obtained, depth measurements from the fathometer were confirmed periodically using the total depth readings from a YSI multiprobe sonde.

Bathymetric maps were created based on the depth readings and location information using ArcGIS to obtain the relationships of lake surface area versus depth for use in model development (**Figure 5.4**). A depth-surface area relationship was then computed using the bathymetric maps, and surface area as a function of stage was obtained using a best-fit polynomial equation based on the relationship. Lake volumes were calculated using surface area and depth within each contour with an interval of 0.5 m. The water volume contained between the shoreline and 0.5-m depth was calculated using the truncated cone method (Wetzel 1983). The calculation was completed for all contour intervals, and a best-fit polynomial equation was established to estimate lake volume as a function of water depth. This method was used by Environmental Consulting and Technology (ECT) for a bathymetric analysis of Lake Apopka (ECT 1989).

Figures 5.5a and **5.5b** show the relationships between water depth and surface area and between water depth and cumulative volume, respectively, for Lake Roberts. The best-fit equations were obtained from the relationships to calculate annual surface area and lake volume as BATHTUB inputs. Monthly lake elevation provided by Orange County was averaged for each year to obtain annual average lake elevation. Based on annual averaged lake levels from 2000 to 2012, lake surface area and lake volume were calculated using the best-fit equations (**Table 5.4**).

Annual lake elevation in Lake Roberts ranged from 107.6 feet (ft) in 2001 to 110.9 ft in 2009, with an average of 109.6 ft, showing that the lake level varied slightly with dry and wet year conditions. During the dry years of 2000 and 2001, the lake level was the lowest over the 12-year period, while the lake level was higher during the wet years in 2008 and 2009. Lake surface area varied as a function of changing lake levels during the period from 2000 to 2012, ranging from

0.40 km² in 2001 to 0.46 km² in 2009, with an average of 0.43 km². Similarly, the lowest lake volume was estimated at 983,036 cubic meters (m³) in 2001, while the peak volume of 1,415,319 m³ was predicted in 2009. Mean depth was calculated by lake surface area and lake volume. Because Lake Roberts is a shallow lake, and assumed to be a well-mixed lake for modeling purposes, the mixed layer depth was assumed to be equal to the mean depth of the lake.

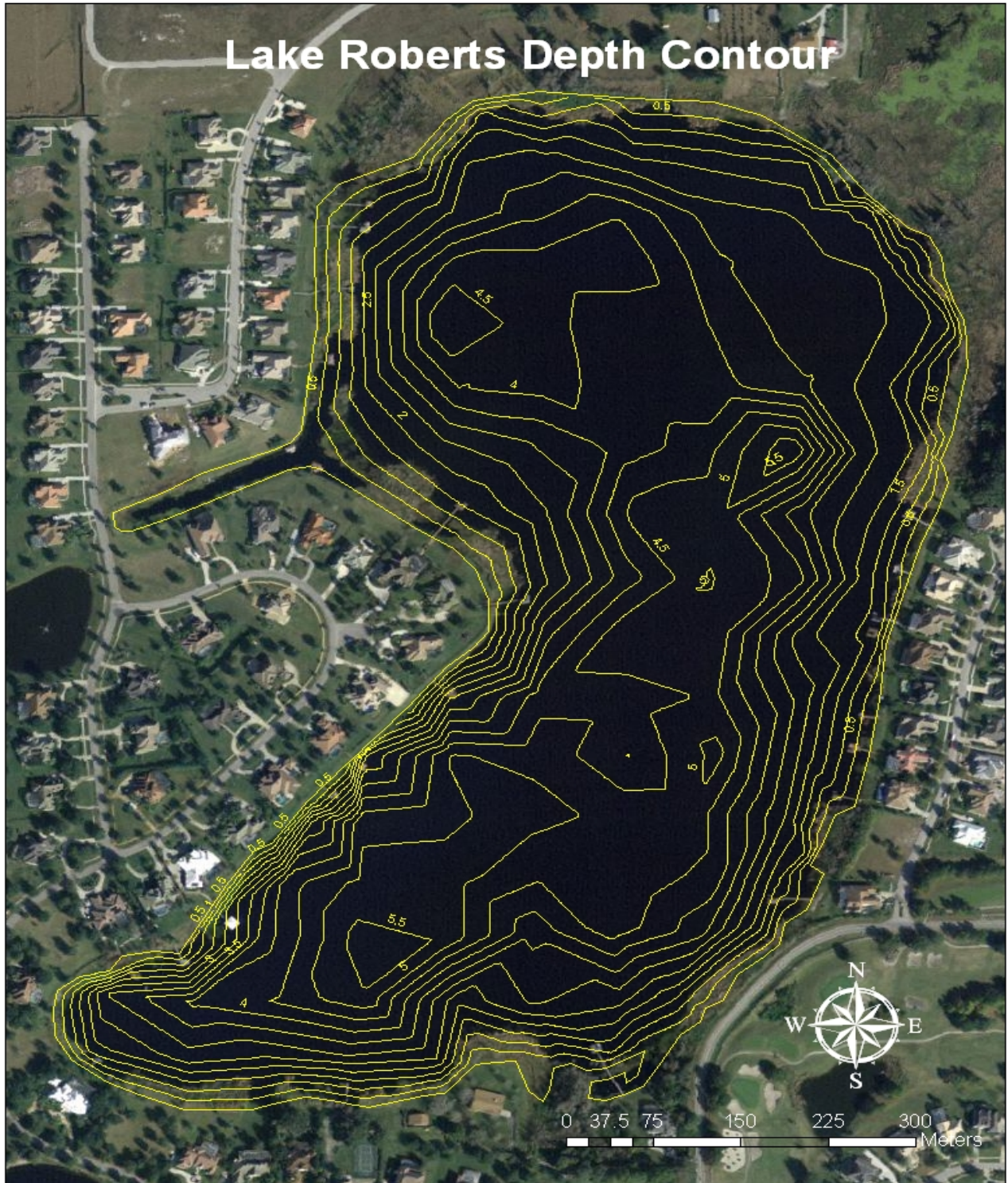

Figure 5.4. Bathymetric map generated for Lake Roberts using ArcGIS. Each contour line represents a 0.5-m depth interval.

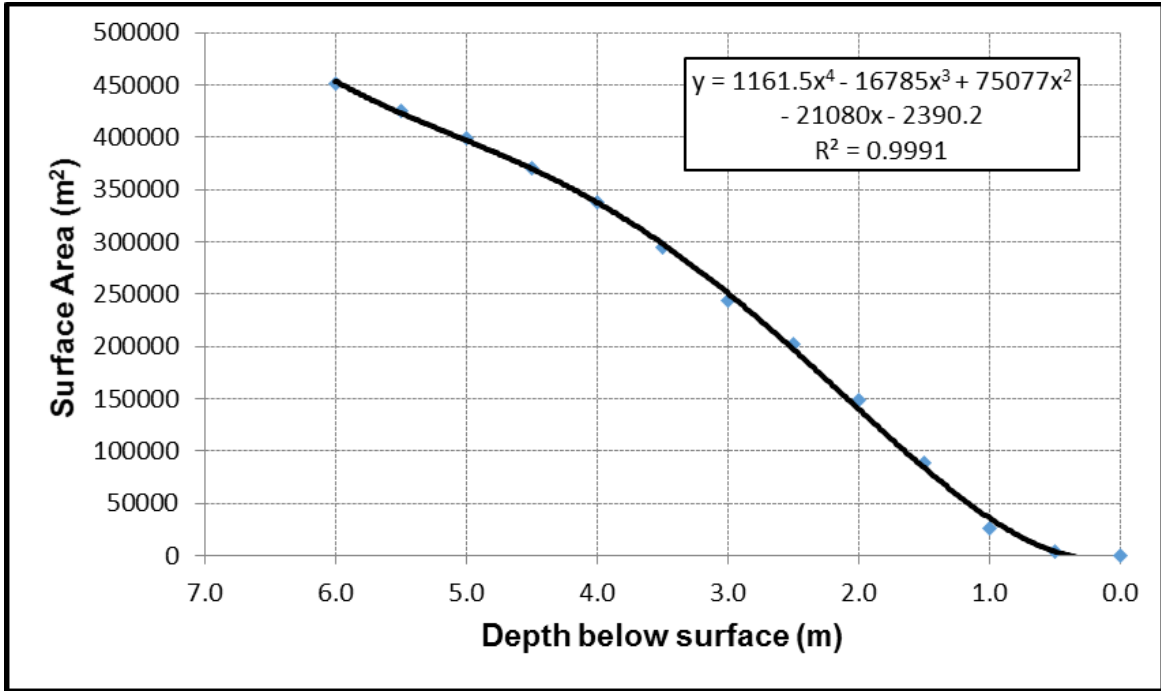

Figure 5.5a. Relationship of depth versus surface area for Lake Roberts. Solid line is a best-fit polynomial line.

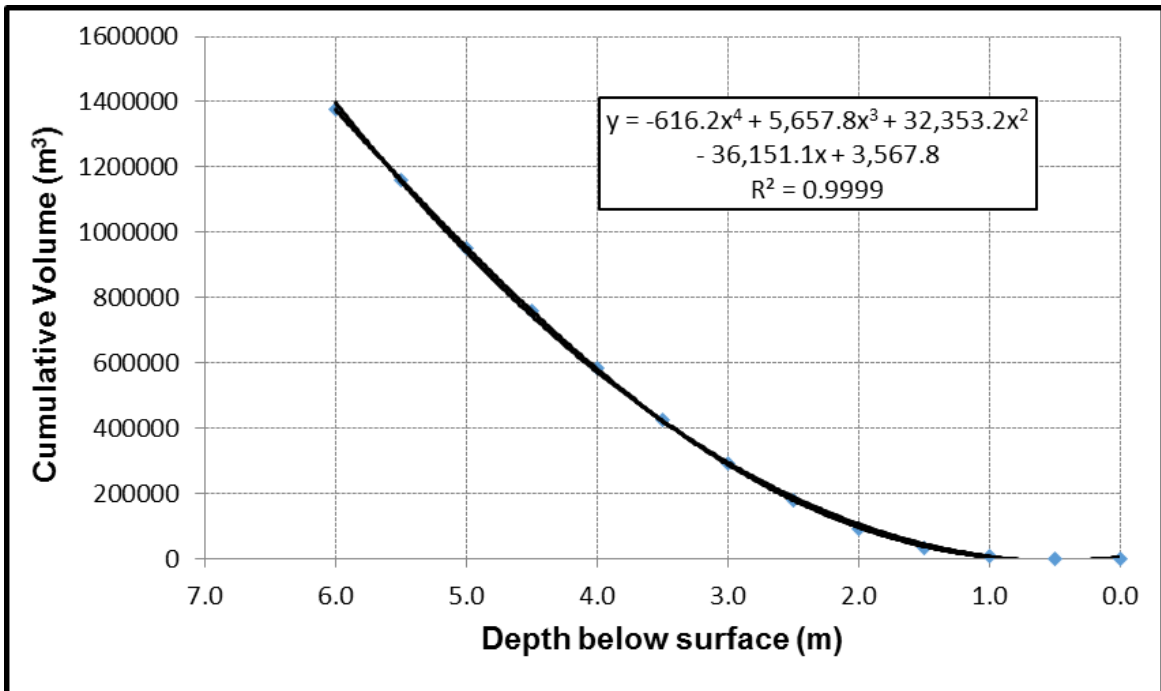

Figure 5.5b. Relationship of depth versus cumulative volume for Lake Roberts. Solid line is a best-fit polynomial line.

Table 5.4. Annual means of morphologic characteristics of Lake Roberts, 2000–12

Year	Annual Average Lake Stage (NGVD, ft)	Annual Average Depth (ft)	Annual Average Depth (m)	Surface Area (m ²)	Surface Area (km ²)	Lake Volume (m ³)	Mean Depth (m)
2000	108.1	17.2	5.23	408,778	0.409	1,047,962	2.56
2001	107.6	16.6	5.07	400,663	0.401	983,036	2.45
2002	109.7	18.8	5.73	435,864	0.436	1,257,075	2.88
2003	110.1	19.1	5.82	441,759	0.442	1,298,190	2.94
2004	109.4	18.4	5.62	429,867	0.430	1,213,273	2.82
2005	110.1	19.2	5.84	442,745	0.443	1,304,868	2.95
2006	109.9	19.0	5.78	439,365	0.439	1,281,734	2.92
2007	109.8	18.9	5.75	437,606	0.438	1,269,430	2.90
2008	110.3	19.4	5.90	447,086	0.447	1,333,584	2.98
2009	110.9	20.0	6.09	460,495	0.460	1,415,319	3.07
2010	110.4	19.5	5.93	448,956	0.449	1,345,613	3.00
2011	109.3	18.4	5.60	428,746	0.429	1,204,875	2.81
2012	109.2	18.3	5.57	426,957	0.427	1,191,352	2.79
Average	109.6	18.7	5.69	434,530	0.435	1,242,024	2.85

5.3.2.2 Meteorological Data

The SJRWMD provided daily NEXRAD rainfall data from January 1, 2000, to December 31, 2012, for TMDL development. The original rainfall data were output for each 2 km² grid at 15-minute intervals. When providing the rainfall data to DEP, the SJRWMD aggregated the 15-minute rainfall into daily rainfall, and a single watershedwide average daily rainfall depth time series was generated by averaging the rainfall depth time series of all the grid cells within the watershed boundary. These daily precipitation data were aggregated into an annual total (in meters per year [m/yr]) for the BATHTUB input (**Table 5.5**).

Pan evaporation is also an important parameter for simulating direct evaporation from the lake surface. The potential evapotranspiration (PET) data were obtained from the Lisbon weather station. Free water surface evaporation from the lake is different from pan evaporation, which can be computed by using methods to correct for the difference in the heat storage capabilities of water in a pan versus in a lake (Lee and Swancar 1997). Lee and Swancar (1997) derived pan coefficients for lakes in central Florida, ranging from 0.70 to 0.77 for Lake Lucerne and 0.71 to 0.75 for Lake Alfred. On an annual basis, the long-term annual average coefficient of 0.74 was derived by Farnsworth et al. (1982).

Trommer et al. (1999) also used a coefficient of 0.75 applied to pan evaporation data from the Bradenton 5 ESE weather station to estimate evaporation for Ward Lake in Manatee County,

Florida. Given the range in Florida values, a pan coefficient of 0.76 was used for the TMDL modeling. **Table 5.5** lists the actual inputs of rainfall and direct evaporation to the model.

The SJRWMD provided direct atmospheric TN and TP deposition data for Lake Roberts. These data were collected from a wet/dry deposition collector operated by the SJRWMD at the Lake Apopka Marshall Flow-Way. The data collected from this site include nitrate/nitrite, total Kjeldahl nitrogen (TKN), and TP concentrations for the wet deposition. The TN concentration was calculated as the sum of nitrate/nitrite and TKN concentrations. Because the SJRWMD concentration data were skewed, an annual median value was calculated for each year based on the measured nutrient concentration for each individual sample. **Table 5.6** shows the annual median TN and TP concentrations for the wet deposition and annual median TN and TP flux for the total (wet + dry) deposition.

Table 5.5. Annual total evaporation and precipitation for Lake Roberts, 2000–12

Year	Lake Evaporation (m/yr)	Precipitation (m/yr)	Difference (m/yr)
2000	1.14	0.63	-0.51
2001	1.10	0.98	-0.12
2002	1.16	1.48	0.32
2003	1.13	1.18	0.05
2004	1.00	1.41	0.41
2005	0.99	1.41	0.41
2006	1.06	1.02	-0.04
2007	1.02	1.04	0.01
2008	1.01	1.42	0.40
2009	1.03	1.52	0.49
2010	1.01	1.25	0.24
2011	1.08	1.05	-0.03
2012	1.05	1.28	0.24
Average	1.06	1.20	0.14

Table 5.6. Direct atmospheric deposition of TN and TP to Lake Roberts, 2000–12

Year	Wet TN Concentration (mg/L)	Wet TP Concentration (mg/L)	Total (Wet + Dry) TN Flux (mg/m ² /yr)	Total (Wet + Dry) TP Flux (mg/m ² /yr)
2000	0.656	0.016	664	37
2001	0.757	0.012	888	22
2002	0.504	0.009	892	25
2003	0.613	0.011	835	26
2004	0.573	0.011	988	33
2005	0.507	0.011	850	30
2006	0.569	0.008	767	24
2007	0.678	0.016	924	44
2008	0.568	0.017	973	47
2009	0.509	0.018	942	50
2010	0.478	0.015	763	49
2011	0.430	0.015	585	35
2012	0.703	0.024	1,196	79
Average	0.580	0.014	867	38

5.3.2.3 Estimates of Annual Groundwater Seepage TN and TP Loadings for BATHTUB

Groundwater inflow is an important means to deliver TN and TP to drainage and seepage lakes (Brock et al. 1982; Belanger and Mikutel 1985; Kang et al. 2005). Even drainage lakes have a significant inflow from groundwater seepage (Lee 1977). For example, Brock et al. (1982) reported that groundwater inputs to Lake Mendota, Wisconsin, were significant, accounting for 30 % of the water budget.

However, estimating groundwater inflow and its nutrient delivery is not easy, and the data for calculating nutrient loads are not readily available. Previous investigations have used different methods to estimate groundwater nutrient inputs: chemical tracers (Lee et al. 1980; Corbett et al. 1999), seepage meters (Lee 1977; Belanger and Mikutel 1985), a simple advection-diffusion model (Kang et al. 2005), and a water balance model (Sutula et al. 2001). For Lake Roberts, no groundwater flow measurements or associated nutrient data were available for the 13-year period for estimating annual groundwater inputs of TN and TP for BATHTUB model simulation.

Recently, Orange County carried out a special study using seepage meters to estimate the mass loadings of TN and TP from groundwater seepage into Lake Roberts. Seepage measurements and nutrient concentrations were collected from nine sites in Lake Roberts, starting in August 2013, and monthly seepage monitoring was conducted over a period of 12 months through September 2014. The monthly monitoring data, including seepage volume and seepage TN and TP concentrations, were provided to DEP for TMDL development. DEP used these data to create

inputs of annual seepage inflow for BATHTUB model simulation, instead of using a single value over the 13-year simulation.

Figure 5.6 shows the locations of installed seepage meters and lake bathymetry. Most of the meters were installed in shallow areas of the lake, but one (Site 8) was installed in a deeper part of the lake bottom at a depth of 18 ft. Monthly seepage flow and TN and TP concentrations were averaged to represent averaged seepage flow and nutrient mean concentrations for each site over the 12-month period.

Figures 5.7 through 5.9 show the averaged seepage rates and mean concentrations of TN and TP for each site. Averaged seepage rates in Lake Roberts ranged from 0.22 liters per square meter per day (L/m²/day) at Site 8 to 3.58 L/m²/day at Site 2. This wide range, averaging 1.2 L/m²/day, showed that lower seepage rates were typically observed in deeper parts of the lake and higher rates were usually observed in the shallow littoral zone. Overall, these observed rates in Lake Roberts are comparable to those (0.45 to 7.43 L/m²/day) monitored in Spring Lake in Orlando (Environmental Research and Design [ERD] 2008). In particular, measurements from a seepage meter installed at a depth of 5 m ranged from 0.09 to 0.37 L/m²/yr over the 12-month period, suggesting that seepage rates in the deeper parts of the lake were lower than those in shallow areas.

Typically, overall seepage rate is strongly correlated with water depth or with distance from shore (Brock et al. 1982). Therefore, the calculation of lakewide seepage inflow at depths up to 5 m was determined using the bathymetric relationship between water depth and lake surface area. Ninety percent of the lake is shallower than 5 m, corresponding to the lake area of 386,880 m². Based on the bathymetric information, a lakewide average groundwater seepage rate was calculated at 140 ac-ft/yr during the 12-month period. This annual groundwater seepage rate is similar to that (213 ac-ft/yr) estimated for Spring Lake in Orlando (ERD 2008).

Figures 5.8 and 5.9 show averaged seepage concentrations of TN and TP. In general, higher nutrient concentrations were found at the sites with slower seepage rates, except for Site 5. The average concentrations of TN and TP at Site 5, which is located near wetlands, were the highest, measuring 7.63 mg/L for TN and 0.857 mg/L for TP. Whole-lake average seepage concentrations of TN and TP were 4.23 and 0.346 mg/L, respectively, significantly higher than ambient surface water concentrations of TN (1.21 mg/L) and TP (0.047 mg/L) in the lake. Whole-lake average seepage TN and TP concentrations were used to calculate groundwater seepage loads into the lake.

Whole-lake average groundwater seepage loads of TN and TP obtained from seepage meter measurements provided DEP with only a one-year estimate of TN and TP loading, from October 2013 to September 2014. However, BATHTUB model simulation is required to have annual inputs for groundwater inflow from 2000 to 2012. Moreover, Lake Roberts has experienced extremely dry and wet years, as previously explained, and so annual inputs for BATHTUB

simulation will better represent the conditions of the lake. Therefore, instead of simply applying the annual groundwater seepage loads of TN and TP to the entire simulated period (2000–12) with the same value, a water balance model was constructed to use this observed estimate and better represent dynamic groundwater inflow over the dry and wet periods, as follows:

$$\Delta V = P - E + R + S_{in} - L_{out} \quad \text{Equation 3}$$

Where,

ΔV = Change in lake storage volume.

P = Direct rainfall on the lake.

E = Lake evaporation.

R = Runoff volume from the watershed.

S_{in} = Seepage into the lake (groundwater input).

L_{out} = Seepage out and lake outflow.

Appendix C contains calculated monthly water budgets. Although seepage inflow (S_{in}) and lake outflow (L_{out}) including seepage outflow from 2000 to 2012 are unknown, the sum of the annual seepage inflow and lake outflow ($S_{in} - L_{out}$) volume was inversely correlated with annual rainfall during the 13-year period, showing a correlation coefficient (r^2) of 0.578 (**Figure 5.10**). Based on the best-fit equation, the sum of ($S_{in} - L_{out}$) for the period of seepage inflow collection was estimated by using rainfall data collected from September 1, 2013, to August 30, 2014. During this period, recorded rainfall was 49.8 in/yr, and the corresponding sum of annual ($S_{in} - L_{out}$) volume was -638 ac-ft/yr. Observed whole-lake seepage inflow (S_{in}) using seepage meters was estimated at 140 ac-ft/yr during this period, resulting in a lake outflow volume (L_{out}) of -778 ac-ft/yr. As a result, the ratio of S_{in} to L_{out} was 0.18, implying that on average, seepage inflow (S_{in}) may account for 18 % of the volume of lake outflow (L_{out}).

Assuming that Lake Roberts maintained its lake level with a relation of $S_{in} =$ the sum of ($S_{in} - L_{out}$) + (the sum of ($S_{in} - L_{out}$)/0.82) over the 13-year period, annual seepage inflow each year during the period of BATHTUB simulation was calculated, as listed in **Table 5.7**. Calculated annual groundwater seepage inflow represented a reasonable trend of showing lower seepage inflows of 68 ac-ft/yr in 2000 and 40 ac-ft/yr in 2001 during the dry years, and higher seepage rates of 200 ac-ft/yr in 2008 and 187 ac-ft/yr in 2009 during the wet years, with a 13-year long-term average of 132 ac-ft/yr. **Figure 5.11** shows the annual variation of calculated groundwater seepage inflow related to direct rainfall to Lake Roberts. The calculated annual groundwater seepage flow of each year and observed groundwater seepage concentrations of TN and TP were used for the BATHTUB simulation.

5.3.3 BATHTUB Calibration

For TN and TP prediction, the subroutines of nutrient sedimentation models in BATHTUB were used to estimate the net removal of TN and TP from the waterbody. Although a second-order decay model in BATHTUB is the most generally applicable formulation representing TP and TN sedimentation in reservoirs (Walker 1987), a second-order nutrient available model (Model 1) and Bachmann Flushing (Model 5) for Lake Roberts performed better in predicting in-lake concentrations of TP and TN, respectively. In particular, in-lake TP concentrations are significantly correlated with in-lake Chla concentrations, suggesting that the availability of P should be taken into account in selecting the TP and Chla models. Therefore, DEP selected Model 1 for TP and Model 5 for TN to perform mass balance calculations on TP and TN from stormwater runoff, groundwater inputs, in-lake sedimentation, and lake outflow. It should be noted that calibration factors were not applied to fit the model prediction to the observed TN and TP data.

The prediction of Chla concentrations can be based on 1 of the 5 submodels in BATHTUB. Observed TN/TP ratios in Lake Roberts indicated that the lake was co-limited by both N and P for algae growth. However, phosphorus has a much stronger relationship with Chla than nitrogen. Chla Model 5 in BATHTUB accounted for the effects of stronger TP limitations on Chla levels. Sensitivity analyses on Chla concentrations indicated that Model 5 predicted Chla concentrations closer to observed Chla concentrations in Lake Roberts, except for 2000 and 2001 (dry years). During the dry years, the lake had a longer residence time of 5 years in 2000 compared with 10 to 16 months in the wet years.

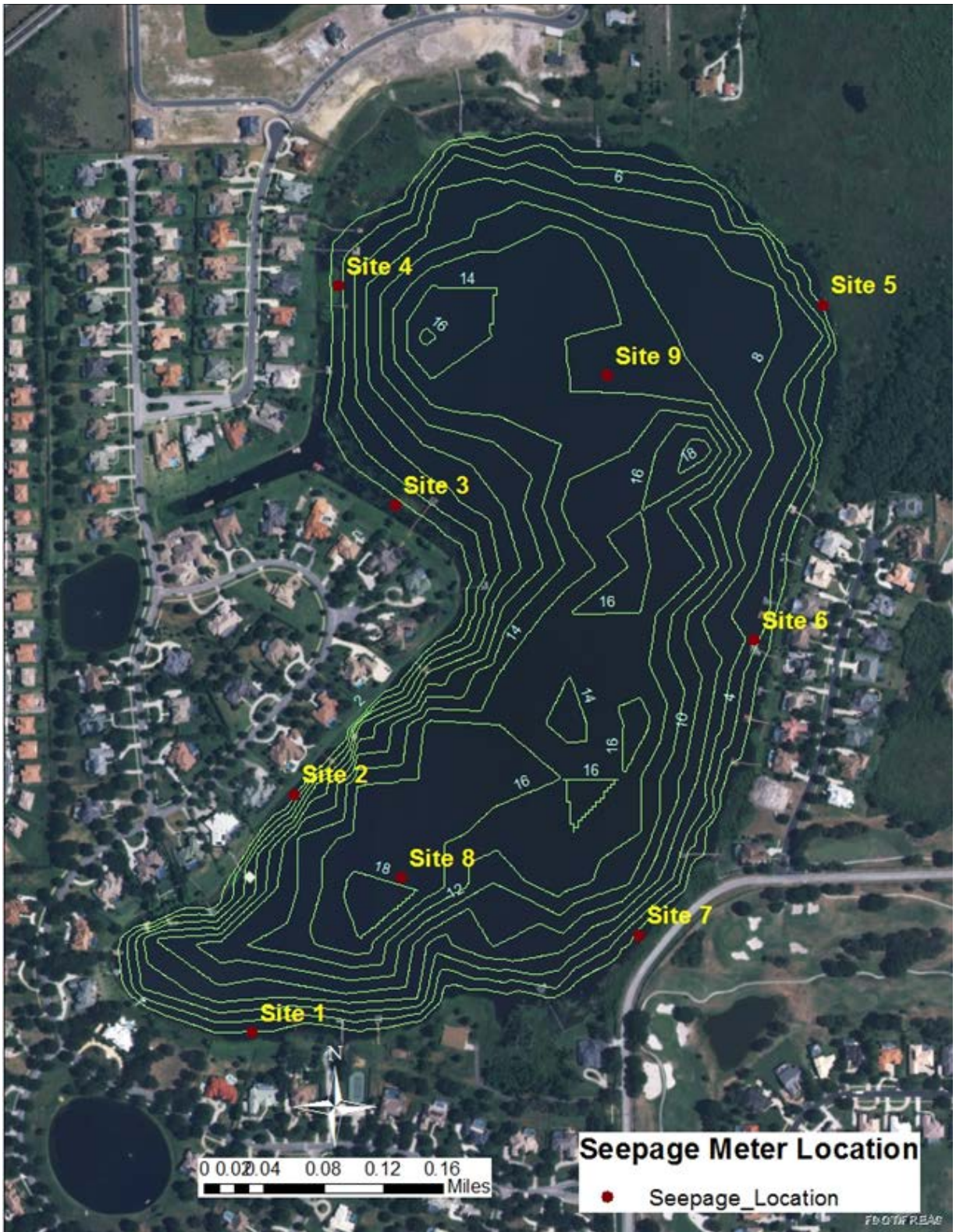

Figure 5.6. Locations of seepage meters installed in Lake Roberts in August 2013

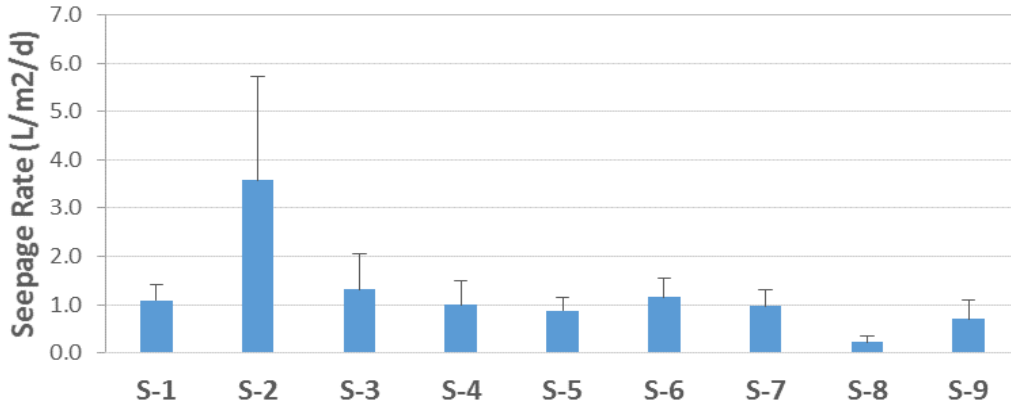

Figure 5.7. Seepage rate and standard deviation averaged from monthly monitoring data collected from each station

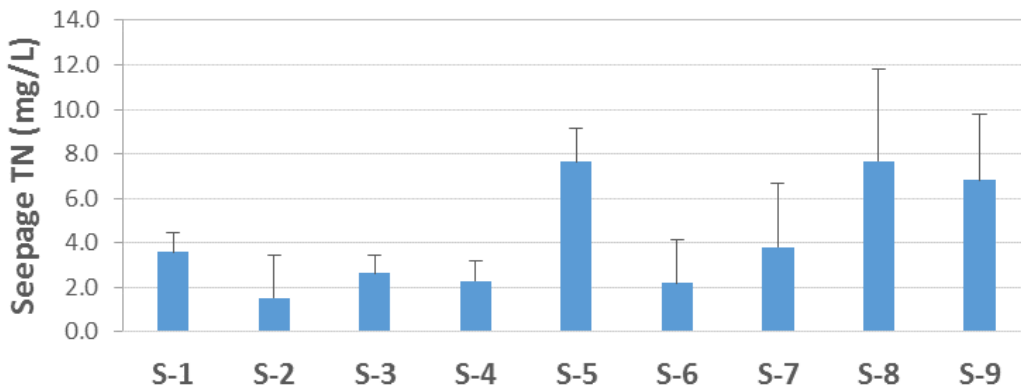

Figure 5.8. Seepage TN and standard deviation averaged from monthly monitoring data collected from each station

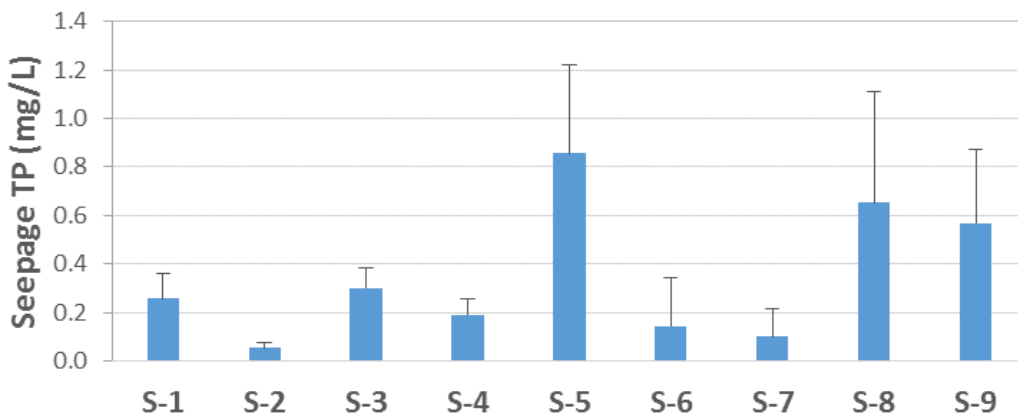

Figure 5.9. Seepage TP and standard deviation averaged from monthly monitoring data collected from each station

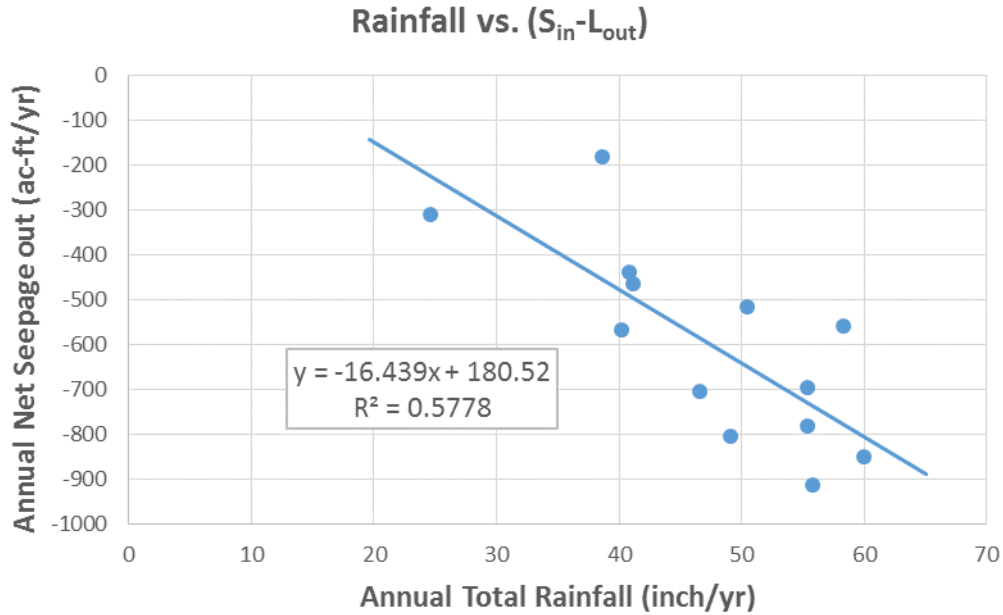

Figure 5.10. Relationship between annual total rainfall versus the sum of annual seepage-inflow minus annual lake outflow ($S_{in} - L_{out}$), 2000–12

Table 5.7. Calculated groundwater seepage inflow (ac-ft/yr) to Lake Roberts, 2000–12

Year	Rainfall (in)	Sum of Rainfall (ac-ft)	Sum of Annual ($S_{in}-L_{out}$) Volume (ac-ft)	Seepage Inflow (S_{in}) (ac-ft)
2000	25	206	-309	68
2001	39	318	-182	40
2002	58	526	-560	123
2003	47	422	-705	155
2004	55	505	-782	172
2005	55	506	-696	153
2006	40	363	-568	125
2007	41	365	-438	96
2008	56	515	-913	200
2009	60	571	-851	187
2010	49	457	-806	177
2011	41	362	-465	102
2012	50	442	-516	113
Average	47	428	-599	132

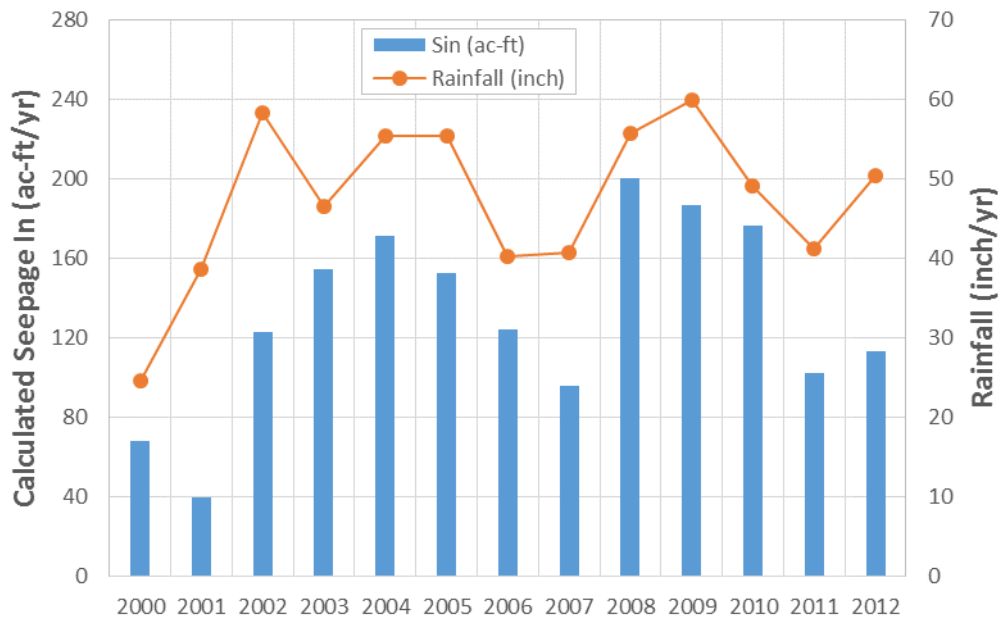

Figure 5.11. Relationship between annual total rainfall versus the sum of annual seepage inflow minus annual lake outflow ($S_{in} - L_{out}$), 2000–12

Due to the noticeably different, longer residence time for 2000 and 2001, the lake probably had different *Chla* responses to less phosphorus and nitrogen inputs and longer attenuation. Therefore, based on the sensitivity analysis, *Chla* Model 3 (P, N, low turbidity) with associated TN and TP models was used for the dry years of 2000 and 2001. Considering co-limitation on algal responses, the N fixation of atmospheric nitrogen by blue-green algae for Lake Roberts was not considered because of positive retention coefficients for TN (*i.e.*, watershed inflow TN is similar to or greater than outflow TN) and co-limitation by both TN and TP in both inflows and the lake. It should also be noted that calibration factors were not applied to fit the *Chla* model prediction to the observed *Chla* data.

Figures 5.12 through 5.17 show the predicted versus observed concentrations of annual TN, TP, and *Chla*. Long-term averages of annual TN and TP were predicted to be $1,121 \pm 96$ and 49.2 ± 10.9 parts per billion (ppb), respectively. The predicted 13-year averages are similar to those of observed TN ($1,192 \pm 130$ ppb) and TP (44 ± 14 ppb). The predicted *Chla* concentrations are also consistent with observed *Chla* concentrations. The long-term average of *Chla* was predicted to be 25 ± 6.5 ppb, comparable to the observed value of 26 ± 14.3 ppb. Overall, no observed TN, TP in 2004 and no *Chla* data in 2000 and 2004 were available for model calibration.

Annual mean concentrations of TN, TP, and *Chla* predicted by BATHTUB are comparable to the annual concentrations observed for Lake Roberts, within the CV and the long-term means with 95 % confidence intervals. Therefore, it was decided that the BATHTUB model was considered

calibrated for Lake Roberts. Based on the calibrated model, current watershed loads of TN and TP were estimated from 2000 to 2012, as shown in **Tables 5.8** and **5.9**. Watershed TP loads ranged from 27 kg/yr in 2000 to 106 kg/yr in 2009. The long-term average TP load to the lake was estimated to be 66 kg/yr from the watershed, 56 kg/yr from groundwater seepage, and 17 kg/yr from direct precipitation. These are similar to the groundwater contribution (**Table 5.7**), accounting for an average of 48 % of total loads of TP over the prediction period (**Figure 5.18**). The contribution of watershed TN loads was predominant, ranging from 402 kg/yr in 2000 to 1,370 kg/yr in 2009, with a long-term average load of 911 kg/yr. This watershed load of TN accounted for 46 % of total incoming TN loads to the lake during the period of prediction.

Groundwater seepage was the second largest contributor, delivering 35 % of the total TN loads to Lake Roberts (**Figure 5.19**). A portion of the incoming TN was retained in Lake Roberts, accounting for 45 %, while a majority of the incoming TN, accounting for 55 %, was removed from the lake via outgoing and seepage outflows.

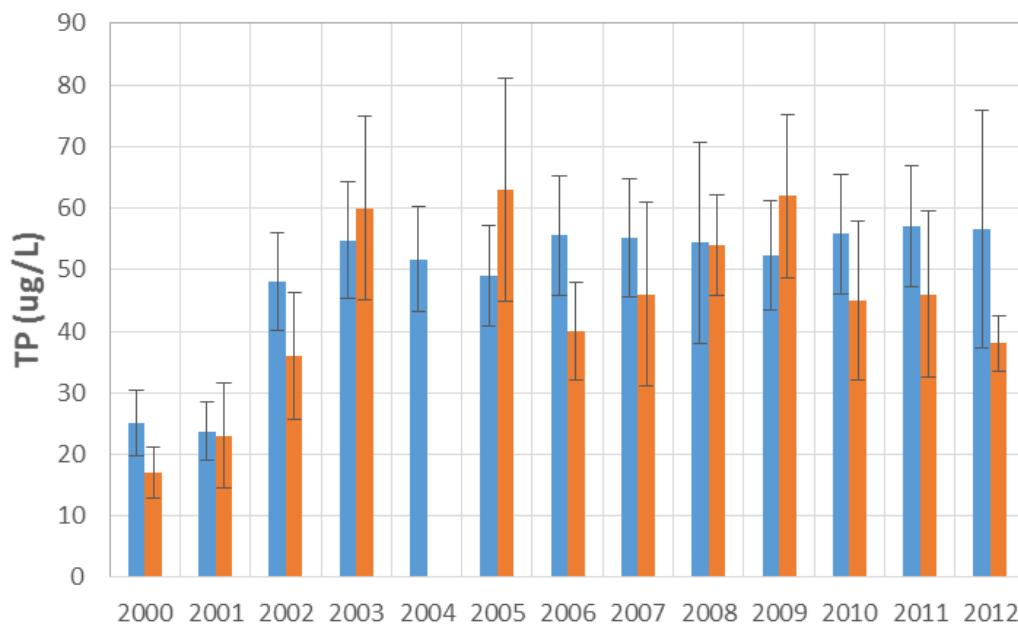

Figure 5.12. Calibration of simulated annual TP (blue bars) with observed annual TP (orange bars) in Lake Roberts, 2000–12

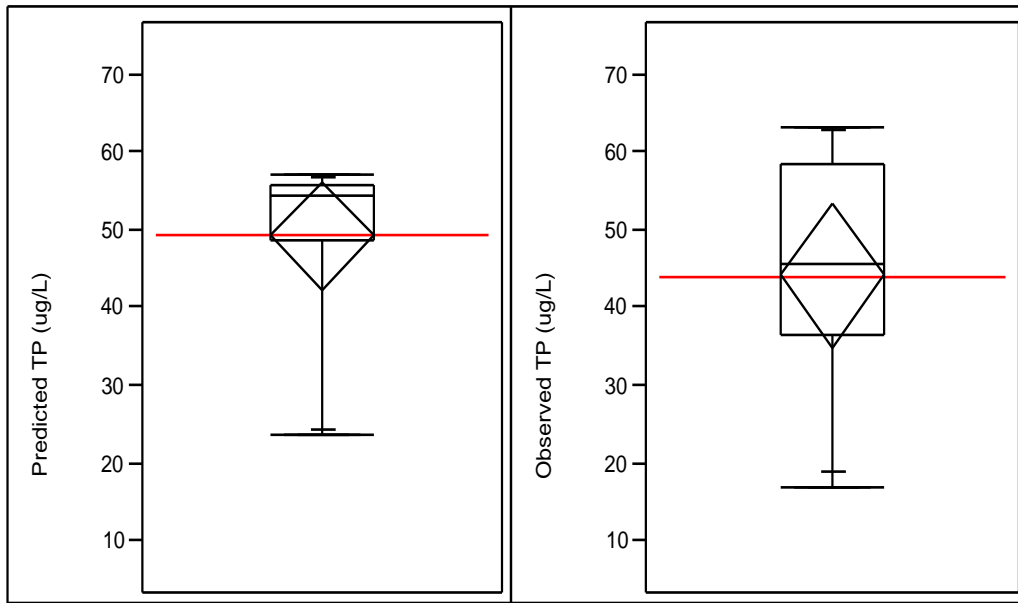

Figure 5.13. Box and whisker plot of simulated versus observed TP in Lake Roberts. The red line and diamond represent a long-term mean with 95 % confidence levels.

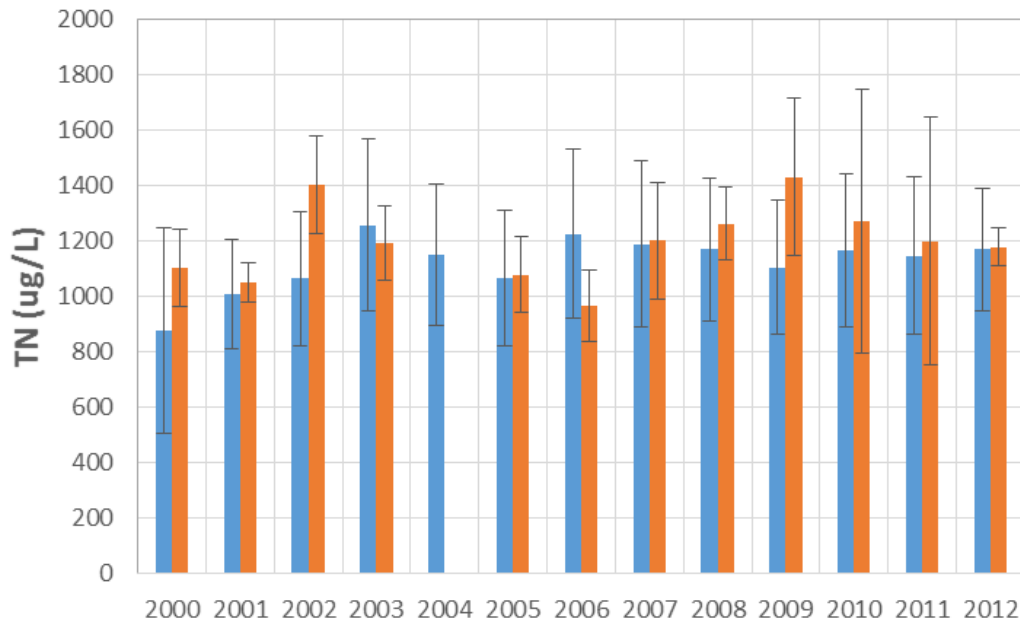

Figure 5.14. Calibration of simulated annual TN (blue bars) with observed annual TN (orange bars) in Lake Roberts, 2000–12

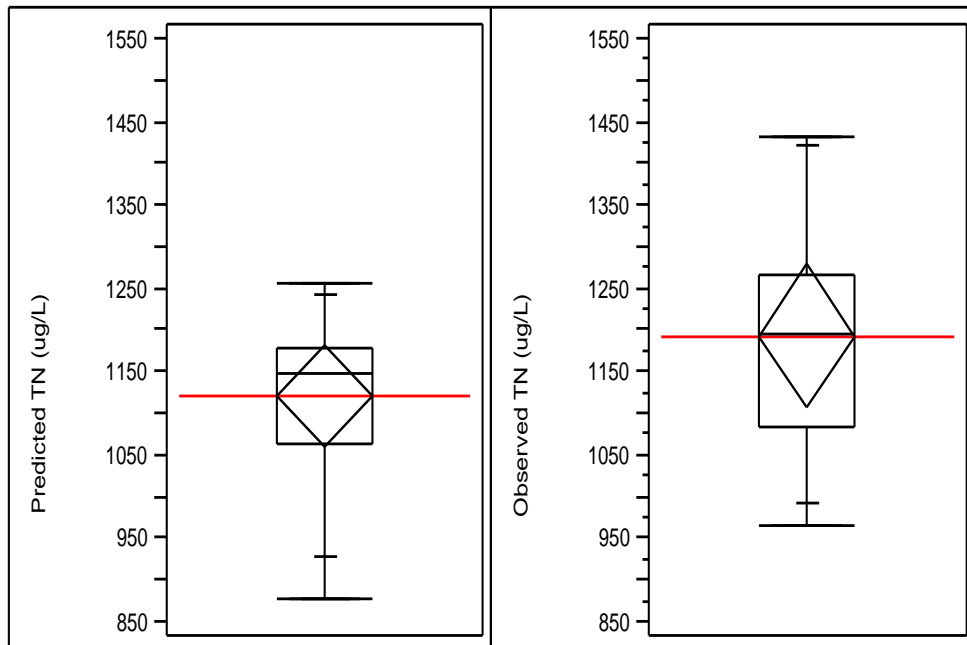

Figure 5.15. Box and whisker plot of simulated versus observed TN in Lake Roberts. The red line and diamond represent a long-term mean with 95 % confidence levels.

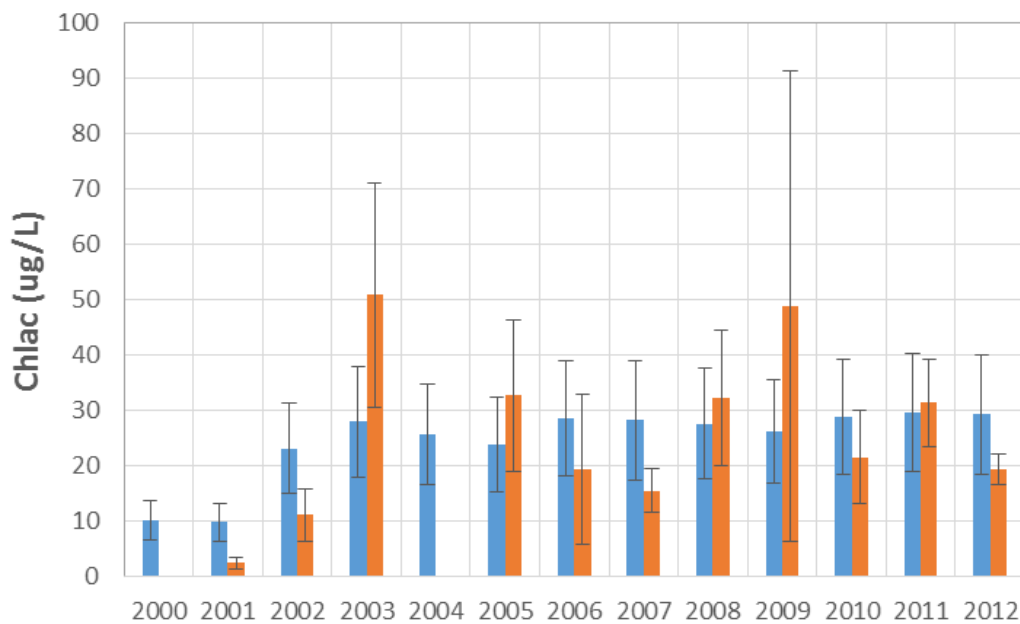

Figure 5.16. Calibration of simulated annual Chla (blue bars) with observed annual Chla (orange bars) in Lake Roberts, 2000–12

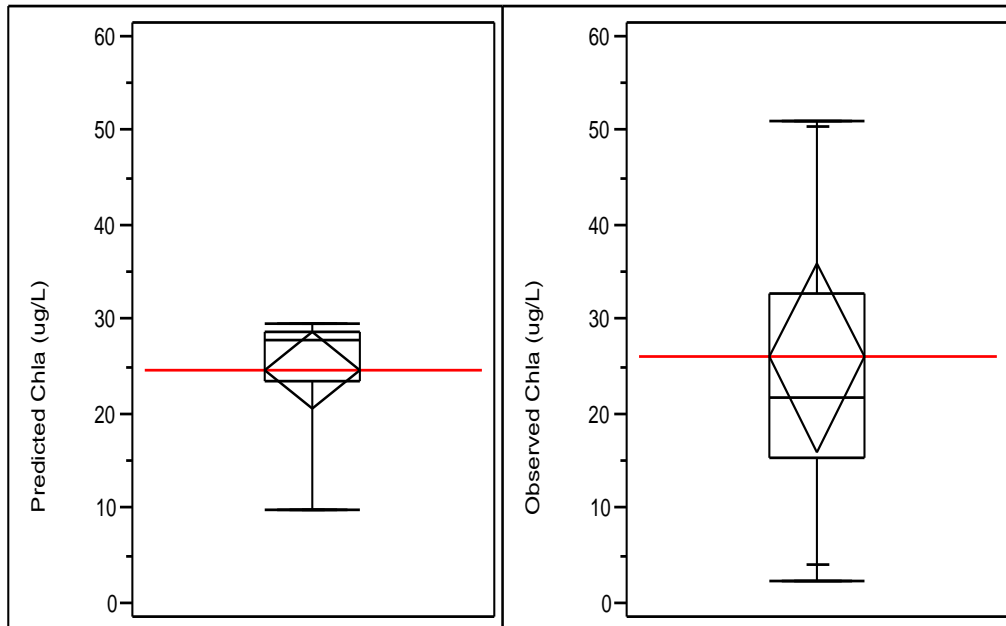

Figure 5.17. Box and whisker plot of simulated versus observed Chla in Lake Roberts. The red line and diamond represent a long-term mean with 95 % confidence levels.

Table 5.8. Calibrated TP mass balance for Lake Roberts, 2000–12

Year	TP Load from Watershed (kg/yr)	TP Load from Precipitation (kg/yr)	TP Groundwater Seepage Loads (kg/yr)	TP Retention (kg/yr)	TP Outflow (kg/yr)
2000	27	15	29	66	5
2001	42	9	17	55	12
2002	74	11	53	82	55
2003	51	11	66	83	46
2004	72	14	73	97	63
2005	66	13	65	88	57
2006	62	11	53	81	44
2007	57	19	41	76	42
2008	97	21	85	127	76
2009	106	23	80	130	79
2010	69	22	75	107	59
2011	67	15	44	80	45
2012	70	34	48	97	56
Long-Term Average	66	17	56	90	49

Table 5.9. Calibrated TN mass balance for Lake Roberts, 2000–12

Year	TN Load from Watershed (kg/yr)	TN Load from Precipitation (kg/yr)	TN Groundwater Seepage Load (kg/yr)	TN Retention (kg/yr)	TN Outflow (kg/yr)
2000	402	272	355	851	179
2001	625	356	207	674	515
2002	1,075	389	643	883	1,224
2003	773	369	808	892	1,059
2004	1,043	425	897	967	1,398
2005	964	377	795	902	1,234
2006	832	335	651	839	980
2007	779	405	503	787	900
2008	1,259	435	1,045	1,107	1,632
2009	1,370	433	973	1,117	1,659
2010	925	343	922	954	1,236
2011	868	251	533	755	897
2012	922	513	592	874	1,153
Long-Term Average	911	377	687	892	1,082

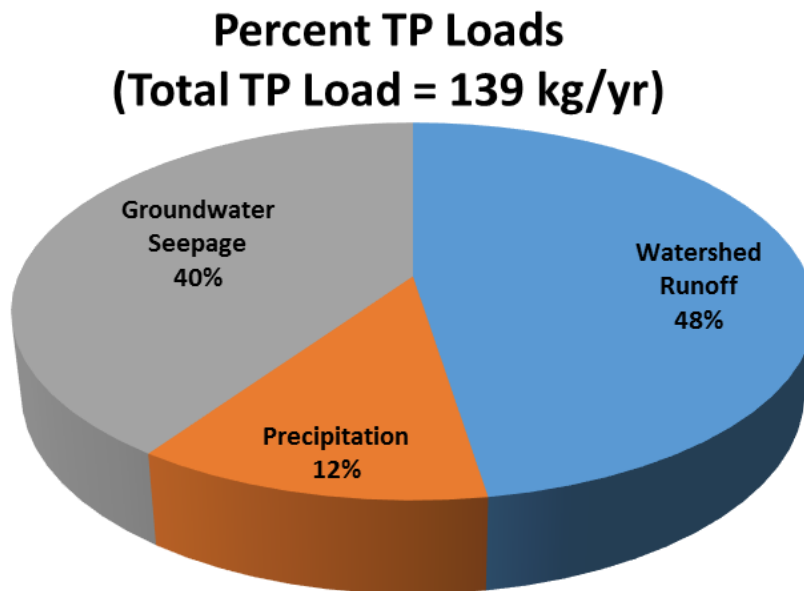

Figure 5.18. Percent contribution of average annual TP loads from various pathways to Lake Roberts, 2000–12

Percent TN Loads (Total TN Load = 1974 kg/yr)

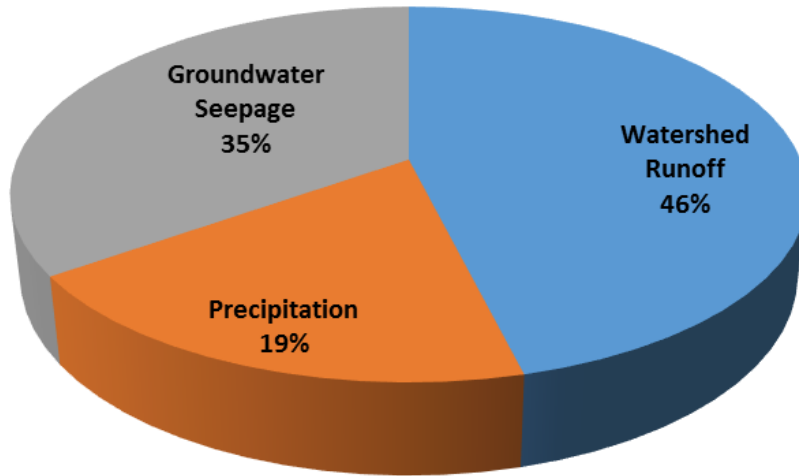

Figure 5.19. Percent contribution of average annual TN loads from various pathways to Lake Roberts, 2000–12

5.3.4 Natural Background Conditions To Determine Natural Levels of Chlorophyll a, TN, and TP

The natural land use background conditions for the Lake Roberts watershed were established to ensure that the proposed TN and TP targets will not abate the natural background condition. For this simulation, all anthropogenic land uses were converted to forest in the model, and anthropogenic groundwater seepage inputs of TN and TP from septic tanks were removed from current groundwater seepage TN and TP loadings to the lake. The other characteristics of the background model remained the same as the current condition.

Simulated annual average concentrations of Chl_a, TN, and TP for the natural background condition from 2000 to 2012 were converted to AGMs for each year using the linear relationships between annual average concentrations and AGM from the lake dataset used in developing the NNC (Ken Weaver, DEP, personal communication, January 15, 2015). **Figure 5.20** shows the linear relationship and best-fit equation obtained using the dataset. Annual average concentrations and calculated AGMs of observed TN and TP for Lake Roberts were plotted on the linear regressions. The figure confirms that observed TN and TP data for Lake Roberts fall along the best-fit lines of TN and TP.

Based on the background model run results (**Figure 5.21**), the predevelopment lake should have AGM TP concentrations ranging from 0.018 to 0.044 mg/L, with a long-term average of 0.035 mg/L. Predevelopment AGM TN concentrations range between 0.76 and 0.97 mg/L, with a long-term average of 0.86 mg/L. Predevelopment AGM Chla ranges from 6.6 to 19.7 µg/L, with an average AGM Chla of 14.8 µg/L, showing that concentrations are lower than the 20 µg/L Chla target over the 13-year simulated period, and indicating that the 20 µg/L Chla target for Lake Robert will not abate the natural background condition.

5.3.5 Load Reduction Scenarios To Determine the TMDLs

The final in-lake TN and TP target concentrations for the restoration of Lake Roberts were determined as the watershed TN and TP loads were reduced iteratively until simulated AGM Chla in Lake Roberts met the Chla NNC of 20 µg/L in each year of the simulation.

For the TP load reduction scenarios, the existing total watershed TP loads were reduced to natural background conditions, and load reduction conditions by 35 % and 32 % of the total watershed loads (**Table 5.10; Figure 5.22**). For TN load reduction scenarios, the existing watershed TN loads were reduced to natural background conditions, and load reduction conditions by 30 % and 20 % of the total watershed loads (**Table 5.11; Figure 5.22**). When the existing watershed TP and TN loads were reduced by 32 % and 20 %, respectively, AGMs of simulated Chla do not exceed the target (20 µg/L) in any single year and result in a long-term average of AGMs of 16.1 µg/L, which is above the long-term natural background level of 14.8 µg/L (**Figure 5.23**). Therefore, it was decided that the model scenario with a 32 % reduction for TP and 20 % for TN from watershed loads meeting the Chla target in each year would be protective of the designated use of Lake Roberts.

Under the TP and TN watershed load reduction condition (the TMDL condition with a 32 % reduction in TP and a 20 % reduction in TN) that meets the Chla target, the AGMs of simulated in-lake TP concentration range from 0.019 to 0.044 mg/L, with a long-term (13-year) average AGM of 0.037 mg/L. For TN, simulated AGMs range from 0.78 to 1.02 mg/L, with a long-term (13-year) average AGM of 0.92 mg/L. It should be noted that under the TMDL condition, the simulated maximum AGMs of TN and TP over the simulation period are all below the minimum values of the TN and TP NNC, not exceeding the NNC in any year. Therefore, the restoration TP and TN targets, expressed as AGMs not to be exceeded in any year, for Lake Roberts that allow the lake to achieve the Chla target are 0.044 and 1.02 mg/L, respectively (**Figure 5.22**). These AGM targets of TN and TP are not to be exceeded to protect the designated use of Lake Roberts.

The final allowable TMDLs for Lake Roberts should be calculated by including all incoming TN and TP loads such as watershed loads, groundwater seepage loads, and atmospheric loads, as shown in **Tables 5.8** and **5.9**. However, the direct atmospheric deposition of TN and TP on the lake surface is not regulated by the Clean Water Act, and was kept the same for the TMDL load

calculation as the existing atmospheric TN and TP deposition. The final TMDL percent reductions were calculated as follows:

$$\text{Percent TN and TP reduction (\%)} = \left\{ 1 - \frac{(W_{tmdl} + G_{tmdl} + P_{atm})}{(W_{existing} + G_{existing} + P_{atm})} \right\} \times 100 \quad \text{Equation 4}$$

Where,

W_{tmdl} and G_{tmdl} are the TMDL TN and TP loads (kg/yr) from watershed runoff and groundwater seepage under the TMDL reduction condition (a 32 % reduction in TP and a 20 % reduction in TN), respectively.

$W_{existing}$ and $G_{existing}$ are the existing TN and TP loads (kg/yr) from watershed runoff and groundwater seepage under the current condition, respectively.

P_{atm} is the existing direct atmospheric deposition of TN and TP to the lake (kg/yr).

Table 5.12 summarizes TN and TP loads from all sources to achieve the target concentrations in Lake Roberts. Therefore, the final allowable TMDLs (i.e., the sum of P_{atm} , W_{tmdl} , and G_{tmdl}) for Lake Roberts are 1,655 kg/yr of TN and 100 kg/yr of TP, which represent a 16 % reduction in TN and a 28 % reduction in TP from all existing incoming loads. These TMDLs will meet the AGM Chla target of 20 µg/L, resulting in AGM TP and TN targets of 0.044 and 1.02 mg/L, not to be exceeded in any year, that will protect the designated use of Lake Roberts.

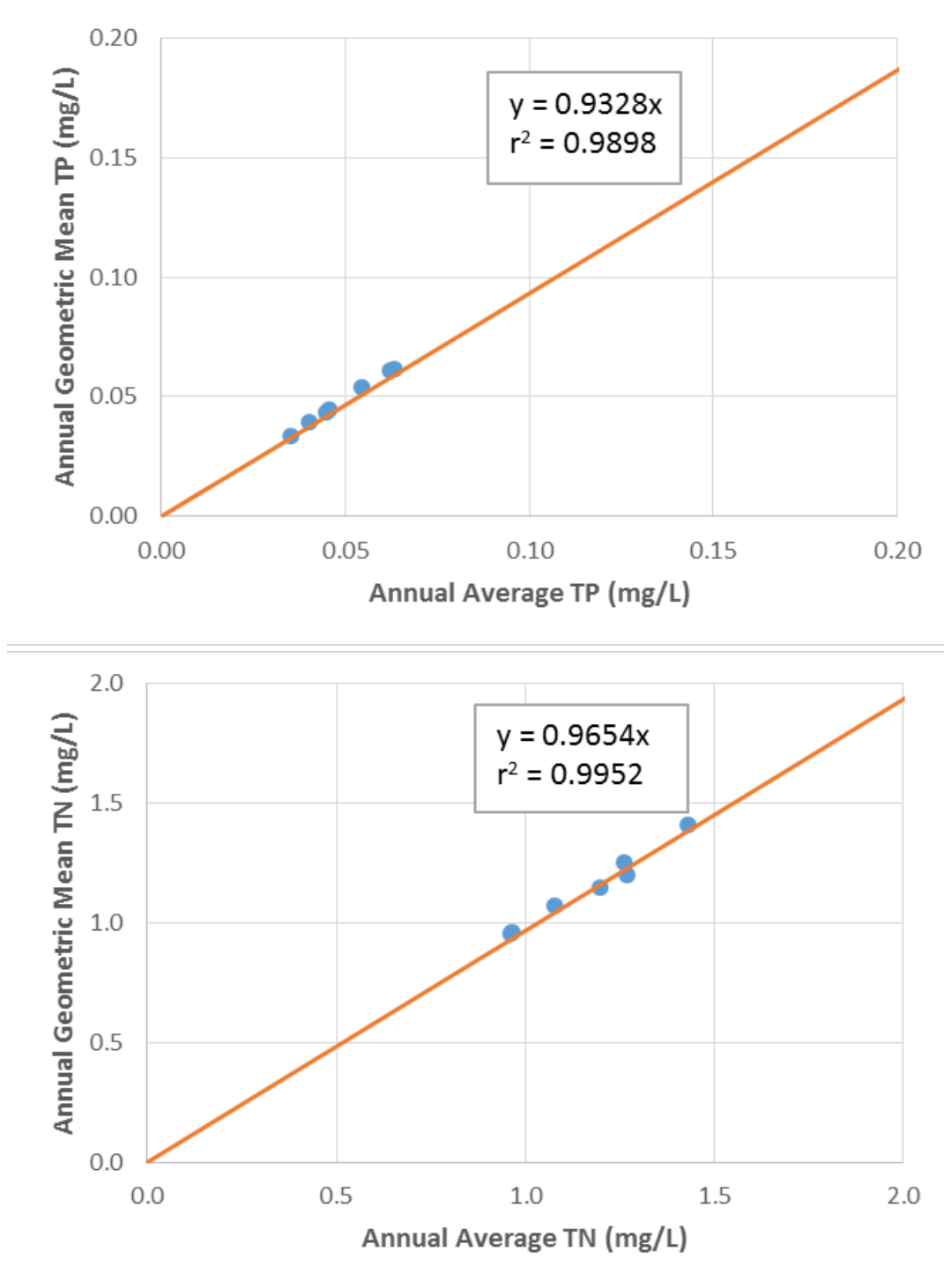

Figure 5.20. Linear relationships between AGMs and annual average concentrations of TP (top) and TN (bottom) used for lake NNC development. The dataset (circles) obtained from the observed data for Lake Roberts were plotted along the regression lines derived from the lake NNC dataset.

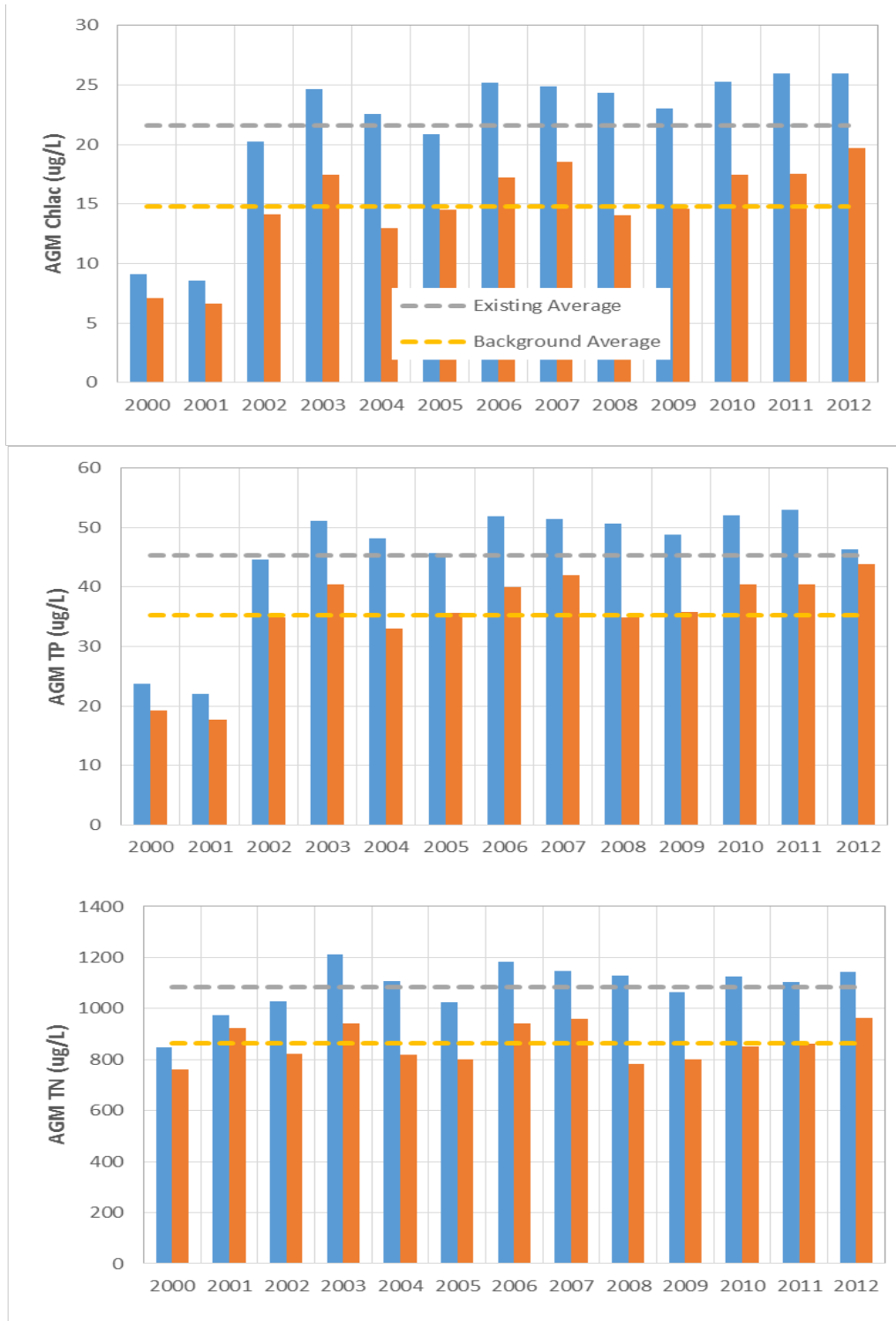

Figure 5.21. AGMs of Chla, TN, and TP for existing (blue bars) versus natural background (orange bars) conditions, 2000–12. Gray and yellow dashed lines represent the long-term averages of existing and natural background conditions, respectively.

Table 5.10. Load reduction scenarios for TP under existing, 35 % reduction, and TMDL conditions (32 % reduction)

Year	Existing Anthropogenic Watershed Loads (kg/yr)	Existing Natural Watershed Loads (kg/yr)	Existing Total Watershed TP Loads (kg/yr)	Allowable TP Loads under 35 % Reduction (kg/yr)	Allowable TP Loads under 32 % Reduction (kg/yr)	Allowable Anthropogenic TP Loads (kg/yr)
2000	10.0	16.6	26.6	17.3	18.1	1.5
2001	16.5	25.2	41.6	27.1	28.3	3.1
2002	33.8	39.7	73.5	47.8	50.0	10.3
2003	21.1	30.6	51.8	33.6	35.2	4.6
2004	34.2	37.6	71.8	46.7	48.8	11.2
2005	28.6	37.4	66.0	42.9	44.9	7.5
2006	36.1	25.8	61.9	40.2	42.1	16.3
2007	31.3	25.6	56.9	37.0	38.7	13.1
2008	62.5	34.6	97.1	63.1	66.0	31.4
2009	69.4	36.9	106.3	69.1	72.3	35.4
2010	40.4	28.6	69.0	44.8	46.9	18.3
2011	41.9	24.5	66.4	43.2	45.2	20.6
2012	41.0	28.9	69.9	45.4	47.5	18.7
Average	35.9	30.1	66.1	42.9	44.9	14.8

Table 5.11. Load reduction scenarios for TN under existing, 30 % reduction, and TMDL conditions (20 % reduction)

Year	Existing Anthropogenic Watershed Loads (kg/yr)	Existing Natural Watershed Loads (kg/yr)	Existing Total Watershed TN Loads (kg/yr)	Allowable TN Loads under 30 % Reduction (kg/yr)	Allowable TN Loads under 20 % Reduction (kg/yr)	Allowable Anthropogenic TN Loads (kg/yr)
2000	101	302	402	282	322	20
2001	168	457	625	438	500	43
2002	355	720	1,075	752	860	140
2003	217	556	773	541	618	62
2004	361	683	1,043	730	835	152
2005	297	667	964	675	771	104
2006	353	479	832	582	665	187
2007	304	475	779	545	623	148
2008	616	644	1,259	882	1,008	364
2009	685	685	1,370	959	1,096	411
2010	395	530	925	648	740	210
2011	412	456	868	607	694	239
2012	401	521	922	645	738	217
Average	359	552	911	637	729	177



Figure 5.22. Simulated AGMs of TP (top) and TN (bottom) for existing (blue bars), natural background (orange bars), and TMDL conditions (green bars). The red line represents the water quality targets of TP and TN in µg/L for Lake Roberts.

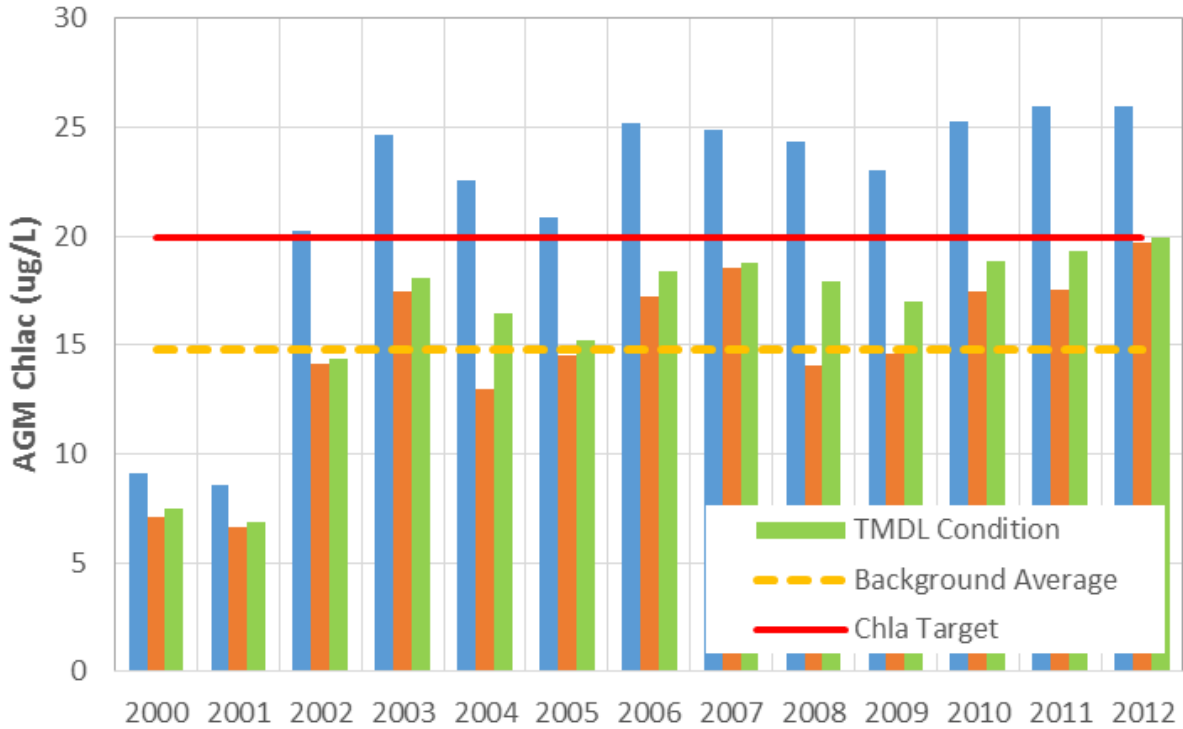

Figure 5.23. Simulated AGMs of Chla for existing (blue bars), natural background (orange bars), and TMDL conditions (green bars). The red line represents the Chla target of 20 µg/L for Lake Roberts.

Table 5.12. TMDL TP and TN loads to achieve the water quality targets for Lake Roberts

Parameter	Existing Watershed Load (kg/yr)	Existing Groundwater Seepage Load (kg/yr)	Direct Atmospheric Load (kg/yr)	TMDL Watershed Load (kg/yr)	TMDL Groundwater Seepage Load (kg/yr)	% Reduction
TP	66	56	17	45	38	28
TN	911	687	377	729	549	16

Chapter 6: Determination of the TMDLs

6.1 Expression and Allocation of the TMDLs

A TMDL can be expressed as the sum of all point source loads (wasteload allocations or WLAs), nonpoint source loads (load allocations or LAs), and an appropriate margin of safety (MOS) that takes into account any uncertainty about the relationship between effluent limitations and water quality.

As mentioned previously, the WLA is broken out into separate subcategories for wastewater discharges and stormwater discharges regulated under the NPDES Program:

$$\text{TMDL} \cong \sum \square \text{WLAs}_{\text{wastewater}} + \sum \square \text{WLAs}_{\text{NPDES Stormwater}} + \sum \square \text{LAs} + \text{MOS}$$

It should be noted that the various components of the TMDL equation may not sum up to the value of the TMDL because (1) the WLA for NPDES stormwater is typically based on the percent reduction needed for nonpoint sources and is accounted for within the LA, and (2) TMDL components can be expressed in different terms (for example, the WLA for stormwater is typically expressed as a percent reduction and the WLA for wastewater is typically expressed as mass per day).

WLAs for stormwater discharges are typically expressed as "percent reduction" because it is very difficult to quantify the loads from MS4s (given the numerous discharge points) and to distinguish loads from MS4s from nonpoint sources (given the nature of stormwater transport). The permitting of MS4 stormwater discharges is also different than the permitting of most wastewater point sources. Because MS4 stormwater discharges cannot be centrally collected, monitored and treated, they are not subject to the same types of effluent limitations as wastewater facilities, and instead are required to meet a performance standard of providing treatment to the "maximum extent practical" through the implementation of best management practices (BMPs).

This approach is consistent with federal regulations (40 CFR § 130.2[I]), which state that TMDLs can be expressed in terms of mass per time (e.g., pounds per day), toxicity, or **other appropriate measure**. The NPDES stormwater WLA is expressed as a percent reduction in the stormwater from MS4 areas. The load allocation and TMDLs for Lake Roberts are expressed as loads and percent reductions, and represent the long-term annual average load of TN and TP from all watershed sources that the waterbody can assimilate and maintain the Class III NNC (**Table 6.1**). The expression and allocation of the TMDLs in this report are based on the loadings necessary to achieve the water quality criteria and designated uses of the surface waters.

These TMDLs are based on simulated long-term (13-year) data from 2000 through 2012. The restoration goal is to restore the AGM Chla concentration in any year to no greater than 20 µg/L.

Table 6.1. TMDL components for Lake Roberts

*The TMDL daily load is 4.5 kg/day for TN and 0.27 kg/day for TP, and corresponding in-lake target AGM concentrations are 1.02 mg/L for TN and 0.044 mg/L for TP, not to be exceeded in any year.

** The required percent reductions listed in this table represent the reduction from all sources. The needed percent reduction to each individual source type can be calculated based on the relative load contribution from each source type provided in **Chapter 5**.

WBID	Parameter	TMDL (kg/yr)	WLA Wastewater (kg/yr)	WLA Stormwater (% reduction)	LA (% reduction)	MOS
2872A	TN	1,655	NA	16	16	Implicit
2872A	TP	100	NA	28	28	Implicit

6.2 Load Allocation (LA)

Because the exact boundaries between those areas of the watershed covered by the WLA allocation for stormwater and the LA allocation are unknown, both the LA and the WLA for stormwater will receive the same percent reduction. The LA is a 28 % reduction in TP and a 16 % reduction in TN of the total nonpoint source loadings based on the period from 2000 to 2012.

As the TMDLs are based on the percent reduction in total watershed loading and any natural land uses are held harmless, the percent reductions for anthropogenic sources may be greater. It should be noted that the LA may include loading from stormwater discharges regulated by DEP and the water management district that are not part of the NPDES Stormwater Program (see **Appendix B**).

6.3 Wasteload Allocation (WLA)

6.3.1 NPDES Wastewater Discharges

As noted in **Chapter 4, Section 4.2.1**, there are no active NPDES-permitted facilities in the Lake Roberts watershed that discharge into the lake or its watershed. Therefore, the WLA_{wastewater} for the Lake Roberts TMDLs is not applicable.

6.3.2 NPDES Stormwater Discharges

The stormwater collection systems in the Lake Roberts watershed, which are owned and operated by Orange County, are covered by an NPDES Phase I MS4 permit (FLS000011). The wasteload allocations for stormwater discharges are a 28 % reduction in TP and a 16 % reduction in TN of the total loading, which are the required percent reductions for the total TN and TP loads from all sources.

It should be noted that any MS4 permittee is only responsible for reducing the anthropogenic loads associated with stormwater outfalls that it owns or otherwise has responsible control over, and it is not responsible for reducing other nonpoint source loads in its jurisdiction. As the

TMDLs are based on the percent reduction in total watershed loading and any natural land uses are held harmless, the percent reduction for only anthropogenic sources may be greater.

6.4 Margin of Safety (MOS)

TMDLs must address uncertainty issues by incorporating an MOS into the analysis. The MOS is a required component of a TMDL and accounts for the uncertainty about the relationship between pollutant loads and the quality of the receiving waterbody (Clean Water Act, Section 303[d][1][c]). Considerable uncertainty is usually inherent in estimating nutrient loading from nonpoint sources, as well as predicting water quality response. The effectiveness of management activities (e.g., stormwater management plans) in reducing loading is also subject to uncertainty. The MOS can either be implicitly accounted for by choosing conservative assumptions about loading or water quality response, or explicitly accounted for during the allocation of loadings.

Consistent with the recommendations of the Allocation Technical Advisory Committee (DEP 2001), an implicit MOS was used in the development of the Lake Roberts TMDLs because they were based on the conservative decisions associated with a number of the modeling assumptions in determining the TMDLs (i.e., loading and water quality response) for Lake Roberts.

Chapter 7: Next Steps: Implementation Plan Development and Beyond

7.1 Implementation Mechanisms

Following the adoption of a TMDL, implementation takes place through various measures. The implementation of TMDLs may occur through specific requirements in NPDES wastewater and MS4 permits, and, as appropriate, through local or regional water quality initiatives or basin management action plans (BMAPs).

Facilities with NPDES permits that discharge to a TMDL waterbody must respond to the permit conditions that reflect target concentrations, reductions, or wasteload allocations identified in the TMDL. NPDES permits are required for Phase I and Phase II MS4s as well as domestic and industrial wastewater facilities. MS4 Phase I permits require that a permit holder prioritize and take action to address a TMDL unless the management actions are already defined in a BMAP. MS4 Phase II permit holders must also implement responsibilities defined in a BMAP.

7.2 Basin Management Action Plans

BMAPs are discretionary and are not initiated for all TMDLs. A BMAP is a TMDL implementation tool that integrates the appropriate management strategies applicable through existing water quality protection programs. DEP or a local entity may develop a BMAP that addresses some or all of the contributing areas to a TMDL waterbody.

Section 403.067, F.S. (FWRA), provides for the development and implementation of BMAPs. BMAPs are adopted by the DEP Secretary and are legally enforceable.

BMAPs describe the management strategies that will be implemented as well as funding strategies, project tracking mechanisms, water quality monitoring, and the fair and equitable allocations of pollution reduction responsibilities to sources in the watershed. BMAPs also identify mechanisms to address potential pollutant loading from future growth and development. The most important component of a BMAP is the list of management strategies to reduce pollution sources, as these are the activities needed to implement the TMDL. The local entities that will conduct these management strategies are identified and their responsibilities are enforceable. Management strategies may include wastewater treatment upgrades, stormwater improvements, and agricultural BMPs. Additional information about BMAPs is available on the [DEP website](#).

7.3 Implementation Considerations for Lake Roberts

In addition to addressing reductions in watershed pollutant contributions to impaired waters during the implementation phase, it may also be necessary to consider the impacts of internal sources (e.g., sediment nutrient fluxes or the presence of nitrogen-fixing cyanobacteria) and the results of any associated remediation projects on surface water quality. In the case of Lake Roberts, other factors such as ratios of seepage inflow to lake outflow, the calibration of watershed nutrient loading, sediment nutrient fluxes, and/or nitrogen fixation are also influencing lake nutrient budgets and the growth of phytoplankton. Approaches for addressing these other factors should be included in a comprehensive management plan for the lake.

References

- Belanger, T.V., and D.F. Mikutel. 1985. On the use of seepage meters to estimate groundwater nutrient loading to lakes. *Water Res. Bull.* 21, 265–272.
- Brock, T.D., D.R. Lee, D. Janes, and D. Winek. 1982. Groundwater seepage as a nutrient source to a drainage lake; Lake Mendota, Wisconsin. *Water Res.* 16, 1255–1263.
- Camp Dresser and McKee Inc. 1994. *City of Jacksonville master stormwater management plan methodology volume*. Final report for the city of Jacksonville and St. Johns River Water Management District. Jacksonville, FL.
- Corbett, D.R., J. Chanton, W. Burnett, K. Dillon, C. Rutkowski, and J.W. Fourqurean. 1999. Patterns of groundwater discharge into Florida Bay. *Limnol. Oceanogr.* 44(4), 1045–1055.
- Dierberg, F.E. 1991. Nonpoint source loadings of nutrients and dissolved organic carbon from an agricultural-suburban watershed in east central Florida. *Water Research* 25, 363–74.
- Environmental Consulting and Technology, Inc. November 1989. *Bathymetric analysis of Lake Apopka*. Report to the St. Johns River Water Management District. Palatka, FL.
- Environmental Research and Design, Inc. 2008. *Spring Lake hydrologic/nutrient budget and management plan*. Final report to the city of Orlando, Florida.
- Fall, C. 1990. *Characterization of agricultural pump discharge quality in the Upper St. Johns River Basin*. Technical Publication SJ90-1. Palatka, FL: St. Johns River Water Management District.
- Fall, C., and J. Hendrickson. 1988. *An investigation of the St. Johns Water Control District: Reservoir water quality and farm practices*. Technical Publication SJ88-5. Palatka, FL: St. Johns River Water Management District.
- Farnsworth, R.K., E.S. Thompson, and E.L. Peck. 1982. *Evaporation atlas for the contiguous 48 United States*. National Oceanic and Atmospheric Administration Technical Report NWS 33.
- Florida Administrative Code. Chapter 62-302, Surface water quality standards.
- . Chapter 62-303, Identification of impaired surface waters.
- Florida Department of Environmental Protection. 2001. *A report to the governor and the legislature on the allocation of total maximum daily loads in Florida*. Tallahassee, FL: Bureau of Watershed Management, Division of Water Resource Management.

———. 2012. *Development of numeric nutrient criteria for Florida lakes, spring vents, and streams*. Technical support document. Tallahassee, FL: Division of Environmental Assessment and Restoration, Standards and Assessment Section.

Florida Department of Health [website](#). 2008.

Florida Department of Transportation. 1999. *Florida Land Use, Cover and Forms Classification System (FLUCCS)*. Tallahassee, FL: Florida Department of Transportation Thematic Mapping Section.

Florida Watershed Restoration Act. *Chapter 99-223, Laws of Florida*.

Fonyo, C., R. Fluck, W. Boggess, C. Kiker, H. Dinkler, and L. Stanislawski. 1991. Biogeochemical behavior and transport of phosphorus in the Lake Okeechobee Basin: Area 3 final report. Vol. 2, Basin phosphorus balances. Gainesville, FL: University of Florida, Institute of Food and Agricultural Sciences.

Fulton, R.S. 1995. *External nutrient budget and trophic state modeling for lakes in the Upper Ocklawaha River Basin*. Technical Publication SJ95-6. Palatka, FL: St. Johns River Water Management District.

Fulton, R.S., C. Schluter, T.A. Keller, S. Nagid, W. Godwin, D. Smith, D. Clapp, A. Karama, and J. Richmond. 2004. *Pollutant load reduction goals for seven major lakes in the Upper Ocklawaha River Basin*. Technical Publication SJ2004-5. Palatka, FL: St. Johns River Water Management District.

German, E.R. 1989. Quantity and quality of stormwater runoff recharged to the Floridan aquifer system through two drainage wells in the Orlando, Florida, area. Water-Supply Paper 2344. Denver, CO: U.S. Geological Survey.

Goldstein, A.J., and R.J. Ulevich. 1981. *Engineering, hydrology, and water quality analysis of detention/retention sites*. Second annual report from the South Florida Water Management District. Tallahassee, FL.

Griffith, G.E., D.E. Canfield, Jr., C.A. Horsburgh, and J.M. Omernik. 1997. *Lake regions of Florida*. EPA/R-97/127. Corvallis, OR: U.S. Environmental Protection Agency.

Harper, H.H. 1994. *Stormwater loading rate parameters for central and south Florida*. Orlando, FL: Environmental Research and Design, Inc.

Harper, H.H., and D.E. Miracle. 1993. *Treatment efficiencies of detention with filtration systems*. Special Publication SJ93-SP12. Palatka, FL: St. Johns River Water Management District.

- Hendrickson, J. 1987. *Effect of the Willowbrook Farms Detention Basin on the quality of agricultural runoff*. Report to the Florida Department of Environmental Regulation. Palatka, FL: St. Johns River Water Management District.
- Hendrickson, J., and J. Konwinski. 1998. *Seasonal nutrient import-export budgets for the lower St. Johns River, Florida*. Report prepared for the Florida Department of Environmental Protection. Palatka, FL: St. Johns River Water Management District.
- Huber, W.C, P.L. Brezonic, J.P. Heaney, R. Dickinson, S. Preston, D. Dwornik, and M. Demaio. 1983. *A classification of Florida lakes*. Complete report to the Florida Department of Environmental Regulation. Report ENV-05-82-1: Gainesville, FL: University of Florida, Department of Environmental Engineering Science.
- Izuno, F.T., C.A. Sanchez, F.J. Coale, A.B. Bottcher, and D.B. Jones. 1991. Phosphorus concentrations in drainage water in the Everglades agricultural area. *Journal of Environmental Quality* 20, 608–19.
- Kang, W-J., K.V. Kolasa, and M.W. Rials. 2005. Groundwater inflow and associated transport of phosphorus to a hypereutrophic lake. *Environmental Geology* 47, 565–575.
- Lee, D.R. 1977. A device for measuring seepage flux in lakes and estuaries. *Limnol. Oceanogr.* 32, 140–147.
- Lee, D.R., J.A. Cherry, and J.F. Pickens. 1980. Groundwater transport of a salt tracer through a sandy lakebed. *Limnol. Oceanogr.* 25, 45–61.
- Lee, T.M., and A. Swancar. 1997. Influence of evaporation, ground water, and uncertainty in the hydrologic budget of Lake Lucerne, a seepage lake in Polk County, Florida. U.S. Geological Survey Water-Supply Paper 2439.
- McCray, J.E., M. Geza, K.F. Murray, E.P. Poeter, and D. Morgan. 2009. *Modeling onsite wastewater systems at the watershed scale: A user's guide*. Alexandria, VA: Water Environment Research Foundation.
- Reckhow, K.H., M.N. Beaulac, and J.T. Simpson. 1980. Modeling phosphorus loading and lake response under uncertainty: A manual and compilation of export coefficients. EPA 440/5-80-011. U.S. Environmental Protection Agency.
- Sutula, M., J.W. Day, J. Cable, and D. Rudnick. 2001. Hydrological and nutrient budgets of freshwater and estuarine wetlands of Taylor Slough in Southern Everglades, Florida (U.S.A.). *Biogeochemistry* 56, 287–310.

Trommer, J., M. DelCharco, and B. Lewelling. 1999. Water budget and water quality of Ward Lake, flow and water-quality characteristics of the Braden River Estuary, and the effects of Ward Lake on the hydrologic system, west-central Florida. U.S. Geological Survey Water-Resources Investigations Report 98-4251. Tallahassee, FL.

U.S. Census Bureau [website](#). 2010.

U.S. Environmental Protection Agency. 1997. *Compendium of tools for watershed assessment and TMDL development*. EPA-841-B-97-006. Washington, DC.

———. 2005. Storm water management model, user's manual Version 5.0. EPA/600/R-05\040. Washington, DC.

Valiela, I., G. Collins, J. Kremer, K. Lajtha, M. Geist, B. Seely, J. Brawley, and C.H. Sham. 1997. Nitrogen loading from coastal watersheds to receiving estuaries: New method and application. *Ecological Applications* 7(2), 358–380.

Viessman, W. Jr., G.L. Lewis, and J.W. Knapp. 1989. *Introduction to hydrology*. Third edition. New York: Harper Collins.

Walker, W.W., Jr. 1987. *Empirical methods for predicting eutrophication in impoundments. Report 4, Phase III: Application manual*. Technical Report E-81-9. Vicksburg, MS: U.S. Army Corps of Engineers, Waterways Experiment Station.

———. 1999. *Simplified procedures for eutrophication assessment and prediction: User manual*. Instruction Report W-96-2. Washington, DC: U.S. Army Corps of Engineers.

Wetzel, R.G. 1983. *Limnology*. Philadelphia, PA: Saunders College Publishing.

Winter, T.C. 1981. Uncertainties in estimating the water balance of lakes: *Water Resources Bulletin* 17(1), 82–115.

Ye, M., and Y. Zhu. 2014. Estimation of groundwater seepage and nitrogen load from septic systems to Lakes Marshall, Roberts, Weir, and Denham. Final report to the Florida Department of Environmental Protection, Tallahassee, FL.

Appendices

Appendix A: Summary of Information Supporting the TMDLs as Site-Specific Interpretations of the Narrative Nutrient Criterion for Lake Roberts

Table A-1. Spatial extent of the waterbody where site-specific numeric interpretations of the narrative nutrient criterion will apply

Location	Description
Waterbody name	Lake Roberts
Waterbody type(s)	Lake
Waterbody ID (WBID)	WBID 2872A
Description	Lake Roberts is located in Orange County, Florida. The estimated average surface area of the lake is 107 acres, with a normal pool volume of 1,242,024 m ³ and an average depth of 5.69 m. Lake Roberts receives runoff from a watershed area of 488 acres occupied by forest/rangeland, urban and residential areas, agriculture, and wetlands. The major sources of water to the lake include surface runoff from the watershed, seepage flow from groundwater, and direct rainfall into the lake. The lake receives water flow from Lake Reaves, located northeast of the lake, through an intermediary wetland.
Specific location (latitude/longitude or river miles)	The center of Lake Roberts is located at Latitude N: 28°31'03", Longitude W: - 81°34'17".
Map	Figure 1.1 and Figures 4.1 and 4.2 show the general location of Lake Roberts and land uses in the watershed, respectively. Land uses include urban and residential (51.9 %), forest/rangeland (2.3 %), agriculture (15.2 %), and water and wetlands (30.6 %).
Classification(s)	Class III Freshwater
Basin name (Hydrologic Unit Code [HUC] 8)	Ocklawaha River Basin (03080102)

Table A-2. Default NNC, site-specific interpretations of the narrative criterion developed as TMDL targets, and data used to develop the site-specific interpretation of the narrative criterion

Narrative Nutrient Criterion	Description
<p>NNC summary: Default nutrient watershed region or lake classification (if applicable) and corresponding numeric nutrient criteria</p>	<p>Lake Roberts is a high-color and high-alkalinity lake, and the generally applicable NNC, expressed as AGM concentrations not to be exceeded more than once in any 3-year period, are Chl_a of 20 µg/L, TN of 1.27 to 2.23 mg/L, and TP of 0.05 to 0.16 mg/L.</p>
<p>Proposed TN, TP, Chl_a, and/or nitrate+nitrite (magnitude, duration, and frequency)</p>	<p>Numeric interpretations of the narrative nutrient criterion: This TMDL is only modifying the default NNC for TN and TP. (The default NNC for Chl_a is not being changed, as DEP has no evidence that the default criterion is not protective of the designated uses of the lake.) The revised TN and TP NNC are expressed as long-term loads. Specifically, the TN load of 1,655 kg/yr and TP load of 100 kg/yr are both expressed as long-term 7-year averages of annual loads not to be exceeded. Watershed model and BATHTUB model simulation with these loadings will result in the default in-lake concentration of 20 µg/L being attained. This approach establishes lake-specific NNC that are more representative of conditions in Lake Roberts than the generally applicable NNC. The TMDL loads will be considered the site-specific interpretation of the narrative criterion. Nutrient concentrations are provided for comparative purposes only.</p>
<p>Period of record used to develop the numeric interpretations of the narrative nutrient criterion for TN and TP criteria</p>	<p>The criteria were developed based on the application of the NRCS curve number model and the receiving water BATHTUB model that simulated hydrology and water quality conditions over the 2000 to 2012 period. The primary datasets for this period include water quality data from the IWR Database (Run 49), rainfall and evapotranspiration data from 2000 to 2012, and lake stage data for 2000 to 2012. Land use data from two years were used to establish watershed nutrient loads. For the 2000 to 2005 simulation period, SJRWMD 2004 land use was used. For the 2006 to 2012 period, SJRWMD 2009 land use was used in the model simulation.</p>
<p>Indicate how criteria developed are spatially and temporally representative of the waterbody or critical condition.</p> <p>Are the stations used representative of the entire extent of the WBID and where the criteria are applied? In addition, for older TMDLs, an explanation of the representativeness of the data period is needed (e.g., have data or information become available since the TMDL analysis?). These details are critical to demonstrate why the resulting criteria will be protective as opposed to the otherwise applicable criteria (in cases where a numeric criterion is otherwise in effect, unlike this case).</p>	<p>The model simulated the 2000 to 2012 period, which included both wet and dry years. During the simulation period, total annual average rainfall varied from 24.6 to 60.0 inches and averaged 47.4 inches. A comparison with the long-term average rainfall data indicated that 2000 and 2001 were dry years, while 2002 and 2006 were wet years.</p> <p>NEXRAD rainfall data that the SJRWMD received from the NWS were used as the model input for estimating nutrient loads from the watershed. These rainfall datasets have a spatial resolution of 2 km², which properly represents the spatial heterogeneity of rainfall in the watershed. The model simulated the entire watershed to evaluate how changes in watershed loads impact lake nutrient and Chl_a concentrations.</p> <p>Figure 5.1 of this report shows the location of a water quality sampling station used in the Lake Roberts model calibration process. The water quality station is situation in the middle of the lake and properly represents a well-mixed lake.</p>

Table A-3. History of nutrient impairment, quantitative indicators of use support, and methodologies used to develop the site-specific interpretation of the narrative criterion

Designated Use	Description
<p>History of assessment of designated use support.</p>	<p>DEP used the IWR to assess water quality for Lake Roberts. The lake was initially verified as impaired for nutrients during the Cycle 3 assessment (verified period January 1, 2005–June 30, 2012) using the methodology in the IWR (Chapter 62-303, F.A.C.), and was included on the Cycle 3 Verified List of impaired waters for the Ocklawaha River Basin adopted by Secretarial Order on February 12, 2013. In addition, DEP assessed the water quality of Lake Roberts using the adopted lake NNC. The results confirmed that Lake Roberts is impaired for nutrients.</p> <p>Chla data from 2000 to 2012 were used to assess the nutrient impairment based on the NNC. There were sufficient Chla data in 2005, and from 2007 through 2010, to meet the data sufficiency requirements of Subsection 62-302.531(6), F.A.C., to calculate the AGM of Chla concentrations. The AGM Chla concentration exceeded the 20 µg/L criterion in several years (2005, 2008, 2009, and 2010), indicating that the lake is impaired for Chla.</p>
<p>Quantitative indicator(s) for use support</p>	<p>The basis for use support is the NNC Chla concentration of 20 µg/L, which is protective of designated uses for high-color lakes. Based on the available information, there is nothing unique about Lake Roberts that would make the use of the Chla threshold of 20 µg/L inappropriate for the lake.</p>
<p>Summarize approach used to develop criteria and how it protects uses</p>	<p>For the Lake Roberts nutrient TMDLs, DEP established the site-specific TN and TP concentrations and loadings using a set of calibrated models to achieve an in-lake Chla AGM concentration of 20 µg/L. Because the 20 µg/L Chla target is the generally applicable NNC demonstrated to be protective of the designated use for high-color, high-alkalinity lakes, the TN and TP concentrations and loading targets established to achieve the 20 µg/L concentration target will also be protective of the designated use.</p>
<p>Discuss how the TMDLs will ensure that nutrient-related parameters are attained to demonstrate that the TMDLs will not negatively impact other water quality criteria. These parameters must be analyzed with the appropriate frequency and duration. If compliance with 47(a) is not indicated in the TMDLs, it should be clear that further reductions may be required in the future.</p>	<p>Model simulations indicated that the target Chla concentration (20 µg/L) in the lake will be attained at the TMDL loads for TN and TP. DEP notes that no other impairments were verified for Lake Roberts that may be related to nutrients (such as DO or un-ionized ammonia). Reducing nutrient loads entering the lake will not negatively impact other water quality parameters of the lake.</p>

Table A-4. Site-specific interpretation of the narrative criterion and protection of designated use of downstream segments

Downstream Protection and Monitoring	Description
<p>Identification of downstream waters: List receiving waters and identify the technical justification for concluding downstream waters are protected.</p>	<p>When water levels are high, Lake Roberts drains to an outlet over a structure located northwest of the lake. The outlet discharges to a residential stormwater pond through an underground pipe. However, there is no defined stream or canal connected to any downstream waters.</p>
<p>Summarize existing monitoring and assessment related to the implementation of Subsection 62-302.531(4), F.A.C., and trends tests in Chapter 62-303, F.A.C.</p>	<p>DEP and Orange County collected water quality data in Lake Roberts. These entities will continue to evaluate future water quality trends in the lake. The data collected through these monitoring activities will be used to evaluate the effect of BMPs implemented in the watershed on the lake's TN and TP concentrations in subsequent water quality assessment cycles.</p>

Table A-5. Public participation and legal requirements of rule adoption

Administrative Requirements	Descriptive Information
<p>Notice and comment notifications</p>	<p>DEP published a Notice of Development of Rulemaking on December 15, 2014, to initiate TMDL development for impaired waters in the Ocklawaha River Basin. A technical workshop for the Lake Roberts TMDLs was held on February 14, 2015, to present the general TMDL approach to local stakeholders. A rule development public workshop for the TMDLs was held on March 20, 2015. Public comments were received for the TMDLs, and DEP is in the process of preparing responses to these comments. DEP published an updated Notice of Development of Rulemaking on April 6, 2015, covering the Ocklawaha River Basin, to address the need for TMDLs to be adopted within one year after the Notice of Development of Rulemaking is published.</p>
<p>Hearing requirements and adoption format used; responsiveness summary</p>	<p>Following the publication of a Notice of Proposed Rule (NPR), DEP will provide a 21 day-challenge period.</p>
<p>Official submittal to the EPA for review and General Counsel certification</p>	<p>If DEP does not receive a rule challenge, the certification package for the rule will be prepared by DEP's program attorney. DEP will prepare the TMDLs and submittal package for the TMDLs to be considered a change to Florida Water Quality Standards, and will submit these documents to the EPA.</p>

Appendix B: Background Information on Federal and State Stormwater Programs

In 1982, Florida became the first state in the country to implement statewide regulations to address the issue of nonpoint source pollution by requiring new development and redevelopment to treat stormwater before it is discharged. The Stormwater Rule, as authorized in Chapter 403, F.S., was established as a technology-based program that relies on the implementation of BMPs that are designed to achieve a specific level of treatment (i.e., performance standards) as set forth in Chapter 62-40, F.A.C. In 1994, DEP's stormwater treatment requirements were integrated with the stormwater flood control requirements of the water management districts, along with wetland protection requirements, into the Environmental Resource Permit (ERP) regulations, as authorized under Part IV of Chapter 373, F.S.

Chapter 62-40, F.A.C., also requires the state's water management districts to establish stormwater PLRGs and adopt them as part of a Surface Water Improvement and Management (SWIM) plan, other watershed plan, or rule. Stormwater PLRGs are a major component of the load allocation part of a TMDL. To date, stormwater PLRGs have been established for Tampa Bay, Lake Thonotosassa, the Winter Haven Chain of Lakes, the Everglades, Lake Okeechobee, and Lake Apopka.

In 1987, the U.S. Congress established Section 402(p) as part of the federal Clean Water Act Reauthorization. This section of the law amended the scope of the federal NPDES permitting program to designate certain stormwater discharges as "point sources" of pollution. The EPA promulgated regulations and began implementing the Phase I NPDES stormwater program in 1990 to address stormwater discharges associated with industrial activity, including 11 categories of industrial activity, construction activities disturbing 5 or more acres of land, and large and medium MS4s located in incorporated places and counties with populations of 100,000 or more.

However, because the master drainage systems of most local governments in Florida are physically interconnected, the EPA implemented Phase I of the MS4 permitting program on a countywide basis, which brought in all cities (incorporated areas), Chapter 298 special districts; community development districts, water control districts, and the FDOT throughout the 15 counties meeting the population criteria. DEP received authorization to implement the NPDES stormwater program in October 2000. Its authority to administer the program is set forth in Section 403.0885, F.S.

The Phase II NPDES stormwater program, promulgated in 1999, addresses additional sources, including small MS4s and small construction activities disturbing 1 and 5 acres, and urbanized areas serving a minimum resident population of at least 1,000 individuals. While these urban stormwater discharges are technically referred to as "point sources" for the purpose of regulation, they are still diffuse sources of pollution that cannot be easily collected and treated by a central treatment facility, as are other point sources of pollution such as domestic and industrial

wastewater discharges. It should be noted that Phase I MS4 permits issued in Florida include a reopener clause that allows permit revisions to implement TMDLs when the implementation plan is formally adopted.

Appendix C: Monthly Water Budget for Lake Roberts, 2000–12

Year	Month	Avg. of Stage (ft)	Avg. of Area (ac)	Ave of Volume (ac-ft)	Sum of Rain Lake (in)	Sum of Evaporation (in)	Rainfall (ac-ft)	Lake Evap. (ac-ft)	Runoff Vol (ac-ft)	S in-S out (ac-ft)	Del Vol (ac-ft)
2000	1	109.3	106.4	973.4	1.36	2.37	12.08	17.7	13.76	-7.1	1.1
2000	2	109.2	106.1	964.7	0.57	2.82	5.01	18.9	6.46	-1.2	-8.7
2000	3	109.0	105.2	940.9	0.27	4.34	2.37	30.5	2.32	1.9	-23.8
2000	4	108.6	103.6	900.1	0.86	4.98	7.43	39.1	9.91	-19.1	-40.9
2000	5	108.1	101.5	847.1	0.81	6.16	6.82	46.4	9.75	-23.1	-52.9
2000	6	107.7	99.7	802.3	3.33	5.94	27.68	45.4	37.21	-64.3	-44.8
2000	7	107.7	99.7	802.3	5.29	5.71	43.95	46.0	57.93	-55.8	0.0
2000	8	107.7	99.7	803.3	5.48	5.51	45.51	44.4	57.68	-57.7	1.0
2000	9	107.8	100.1	812.5	4.52	4.22	37.73	32.4	49.16	-45.3	9.2
2000	10	107.8	100.1	811.5	0.11	3.54	0.92	24.5	1.38	21.2	-1.0
2000	11	107.4	98.5	771.8	1.07	2.69	8.75	17.2	10.91	-42.1	-39.7
2000	12	107.2	97.8	756.6	0.98	2.18	8.01	15.8	9.28	-16.7	-15.2
2001	1	106.9	96.7	731.9	1.55	2.28	12.45	15.5	15.58	-37.3	-24.7
2001	2	107.1	97.3	746.2	0.40	2.79	3.21	17.2	3.88	24.3	14.2
2001	3	106.9	96.7	732.4	6.01	3.91	48.44	25.2	63.15	-100.2	-13.8
2001	4	106.9	96.7	732.4	1.02	5.00	8.25	36.7	9.50	18.9	0.0
2001	5	106.9	96.7	732.4	1.52	5.98	12.21	42.9	16.18	14.5	0.0
2001	6	106.9	96.7	732.4	4.02	5.98	32.36	44.3	42.41	-30.4	0.0
2001	7	106.8	96.1	719.1	6.58	5.35	52.69	41.5	68.68	-93.2	-13.3
2001	8	107.2	97.8	757.5	5.81	5.43	47.34	42.9	62.92	-28.8	38.5
2001	9	108.3	102.2	865.4	9.51	3.91	80.98	30.6	100.83	-43.3	107.9
2001	10	108.7	104.1	912.8	0.94	3.29	8.18	23.7	8.69	54.1	47.3
2001	11	109.2	105.9	959.9	0.92	2.49	8.11	17.2	9.74	46.4	47.1
2001	12	109.0	105.3	942.5	0.39	2.19	3.39	17.1	3.95	-7.6	-17.3
2002	1	108.9	104.6	924.5	0.55	2.49	4.81	18.2	5.85	-10.5	-18.0
2002	2	109.4	106.7	981.5	2.75	2.94	24.42	19.8	28.55	23.9	57.0
2002	3	109.8	108.3	1,027.0	0.59	4.62	5.30	33.3	6.29	67.2	45.5
2002	4	108.7	104.0	910.2	0.70	5.17	6.08	40.8	7.72	-89.7	-116.7
2002	5	108.1	101.5	847.1	1.68	6.22	14.21	46.8	18.32	-48.8	-63.1
2002	6	107.6	99.5	798.3	12.34	5.62	102.31	42.9	137.16	-245.4	-48.9
2002	7	109.9	108.5	1,032.8	6.92	5.96	62.59	52.3	72.09	152.2	234.6
2002	8	110.1	109.6	1,062.2	9.94	5.35	90.75	47.4	105.15	-119.1	29.4
2002	9	110.8	112.3	1,138.1	4.94	4.48	46.28	38.5	54.78	13.3	75.8
2002	10	111.1	113.5	1,170.6	2.76	3.67	26.10	28.8	31.31	3.9	32.5
2002	11	111.1	113.5	1,170.6	1.94	2.66	18.34	19.6	20.06	-18.8	0.0
2002	12	111.1	113.5	1,170.6	13.20	2.21	124.83	18.6	181.50	-287.8	0.0
2003	1	111.3	114.0	1,185.9	0.46	2.30	4.40	18.3	5.09	24.1	15.3

Year	Month	Avg. of Stage (ft)	Avg. of Area (ac)	Ave of Volume (ac-ft)	Sum of Rain Lake (in)	Sum of Evaporation (in)	Rainfall (ac-ft)	Lake Evap. (ac-ft)	Runoff Vol (ac-ft)	S in-S out (ac-ft)	Del Vol (ac-ft)
2003	2	110.2	109.9	1,069.8	1.56	2.92	14.30	20.3	16.77	-126.9	-116.1
2003	3	109.8	108.2	1,024.3	4.12	4.12	37.15	29.7	42.05	-95.0	-45.5
2003	4	109.7	108.1	1,019.4	2.96	5.03	26.61	41.2	29.51	-19.8	-4.9
2003	5	109.7	107.9	1,014.6	2.29	6.12	20.57	49.0	22.11	1.4	-4.9
2003	6	109.0	105.3	943.1	9.26	5.74	81.31	46.3	94.83	-201.3	-71.5
2003	7	109.7	108.0	1,018.9	7.62	5.98	68.64	52.2	79.37	-20.0	75.8
2003	8	110.2	109.9	1,072.0	9.36	5.17	85.79	45.9	118.88	-105.6	53.1
2003	9	111.2	113.7	1,177.1	4.40	4.36	41.67	38.0	47.25	54.2	105.1
2003	10	110.4	110.6	1,090.4	1.64	3.58	15.16	27.4	18.65	-93.1	-86.7
2003	11	109.8	108.3	1,025.4	1.03	2.72	9.34	19.2	12.05	-67.2	-65.0
2003	12	109.5	107.0	989.7	1.90	2.31	16.94	16.1	19.01	-55.6	-35.8
2004	1	109.6	107.4	1,001.6	3.24	2.49	28.99	17.4	30.95	-30.6	11.9
2004	2	109.8	108.1	1,020.0	3.98	2.63	35.88	18.5	44.17	-43.1	18.4
2004	3	110.2	109.7	1,065.5	1.15	4.31	10.50	30.8	11.16	54.6	45.5
2004	4	109.6	107.4	1,001.6	3.97	4.99	35.57	34.8	41.09	-105.7	-63.9
2004	5	99.7	53.0	173.2	0.55	6.06	2.41	20.9	6.29	-816.2	-828.4
2004	6	109.1	105.6	951.7	9.93	6.27	87.40	43.1	105.70	628.5	778.5
2004	7	110.5	111.2	1,105.6	3.15	6.13	29.18	44.3	34.72	134.2	153.8
2004	8	110.2	109.6	1,063.3	11.91	5.36	108.79	38.2	181.83	-294.6	-42.3
2004	9	111.2	113.9	1,181.4	13.23	4.18	125.55	30.9	164.06	-140.6	118.1
2004	10	112.6	119.2	1,328.7	1.47	3.47	14.63	26.9	15.83	143.8	147.3
2004	11	110.6	111.3	1,111.0	1.53	2.59	14.18	18.7	16.00	-229.2	-217.8
2004	12	109.9	108.8	1,039.5	1.32	2.08	11.97	14.7	14.36	-83.1	-71.5
2005	1	109.5	107.1	992.9	2.09	2.36	18.62	16.4	21.95	-70.7	-46.6
2005	2	109.4	106.8	984.2	1.64	2.66	14.58	18.4	16.63	-21.4	-8.7
2005	3	109.3	106.4	972.3	4.50	3.72	39.92	25.7	48.10	-74.2	-11.9
2005	4	109.8	108.3	1,025.4	1.45	5.08	13.13	35.8	14.93	60.8	53.1
2005	5	109.2	105.8	956.1	4.69	6.07	41.30	41.7	49.08	-118.0	-69.3
2005	6	109.5	107.0	989.7	13.25	5.42	118.10	37.7	181.64	-228.5	33.6
2005	7	111.5	115.1	1,213.9	6.59	6.22	63.22	46.5	72.49	135.0	224.3
2005	8	110.9	112.6	1,146.7	7.46	5.94	70.00	43.5	77.28	-171.0	-67.2
2005	9	111.0	112.8	1,151.1	4.63	4.51	43.52	33.1	50.28	-56.4	4.3
2005	10	109.5	107.0	990.7	4.83	3.39	43.11	23.6	51.11	-231.0	-160.3
2005	11	110.9	112.7	1,148.9	1.81	2.67	16.97	19.6	18.59	142.2	158.2
2005	12	110.7	111.7	1,120.2	2.48	2.08	23.05	15.1	25.94	-62.6	-28.7
2006	1	110.4	110.6	1,091.5	0.59	2.55	5.42	18.4	6.93	-22.7	-28.7
2006	2	110.0	109.0	1,046.0	3.32	2.75	30.17	19.5	34.47	-90.6	-45.5
2006	3	109.9	108.6	1,034.1	0.03	4.46	0.23	31.4	0.27	19.0	-11.9

Year	Month	Avg. of Stage (ft)	Avg. of Area (ac)	Ave of Volume (ac-ft)	Sum of Rain Lake (in)	Sum of Evaporation (in)	Rainfall (ac-ft)	Lake Evap. (ac-ft)	Runoff Vol (ac-ft)	S in-S out (ac-ft)	Del Vol (ac-ft)
2006	4	109.3	106.2	966.9	3.00	5.53	26.55	38.1	34.00	-89.6	-67.2
2006	5	109.2	105.9	958.2	2.04	6.52	17.97	44.8	21.99	-3.8	-8.7
2006	6	109.0	105.0	935.7	8.08	6.05	70.73	41.3	92.54	-144.5	-22.6
2006	7	109.8	108.2	1,022.2	9.15	6.15	82.51	43.3	138.98	-91.8	86.5
2006	8	110.8	112.3	1,138.1	3.92	5.92	36.66	43.2	46.99	75.5	115.9
2006	9	110.5	111.0	1,101.2	4.98	4.66	46.03	33.6	56.02	-105.2	-36.8
2006	10	110.5	110.8	1,095.8	0.94	4.03	8.65	29.0	9.86	5.1	-5.4
2006	11	110.0	109.1	1,047.1	1.73	2.51	15.74	17.8	19.57	-66.2	-48.8
2006	12	109.8	108.4	1,027.6	2.47	2.25	22.29	15.8	26.84	-52.8	-19.5
2007	1	110.2	110.0	1,073.1	1.40	2.39	12.83	17.1	17.22	32.5	45.5
2007	2	110.2	109.8	1,067.7	1.02	2.74	9.30	19.5	10.63	-5.8	-5.4
2007	3	109.9	108.7	1,037.3	0.68	4.26	6.16	30.1	7.51	-13.9	-30.3
2007	4	109.4	106.8	983.2	2.01	5.12	17.88	35.5	21.41	-57.9	-54.2
2007	5	109.2	106.1	963.7	1.22	6.02	10.82	41.5	14.66	-3.5	-19.5
2007	6	108.7	103.9	907.2	7.65	6.04	66.23	40.8	92.65	-174.6	-56.5
2007	7	108.8	104.3	917.4	9.18	6.17	79.76	41.8	95.95	-123.7	10.2
2007	8	110.0	109.1	1,049.2	6.66	5.88	60.57	41.7	87.51	25.5	131.9
2007	9	110.5	111.2	1,105.6	5.72	4.62	53.00	33.4	63.37	-26.7	56.3
2007	10	110.5	111.0	1,101.2	3.93	3.38	36.37	24.4	39.59	-55.9	-4.3
2007	11	110.4	110.5	1,087.2	0.33	2.67	3.05	19.2	3.36	-1.3	-14.1
2007	12	110.1	109.4	1,057.9	1.03	2.42	9.40	17.2	11.14	-32.6	-29.3
2008	1	110.0	109.0	1,044.9	3.62	2.41	32.83	17.1	38.17	-66.9	-13.0
2008	2	110.4	110.5	1,086.1	2.15	3.11	19.78	22.3	22.53	21.2	41.2
2008	3	110.3	110.1	1,077.4	3.26	4.19	29.92	30.0	33.59	-42.1	-8.7
2008	4	110.8	112.2	1,134.8	3.47	5.06	32.46	36.9	34.62	27.3	57.4
2008	5	110.2	109.8	1,067.7	1.19	6.15	10.86	43.9	11.62	-45.8	-67.2
2008	6	109.6	107.6	1,007.0	5.98	6.36	53.65	44.5	60.71	-130.5	-60.7
2008	7	109.6	107.5	1,003.7	11.22	5.97	100.47	41.7	140.97	-203.0	-3.3
2008	8	111.2	113.7	1,177.1	16.86	5.13	159.78	37.9	281.82	-230.3	173.3
2008	9	111.9	116.3	1,247.5	2.35	4.42	22.74	33.4	22.84	58.3	70.4
2008	10	110.7	111.8	1,124.0	3.38	3.45	31.52	25.1	37.55	-167.5	-123.5
2008	11	109.7	107.8	1,011.3	1.49	2.52	13.37	17.6	16.08	-124.5	-112.7
2008	12	109.6	107.5	1,002.7	0.88	2.39	7.89	16.7	9.37	-9.2	-8.7
2009	1	109.8	108.4	1,028.7	1.80	2.44	16.27	17.2	18.52	8.4	26.0
2009	2	109.9	108.5	1,030.8	0.65	2.79	5.89	19.7	7.03	8.9	2.2
2009	3	111.0	113.0	1,158.1	0.75	4.31	7.11	31.7	8.17	143.7	127.3
2009	4	111.0	113.0	1,158.1	1.05	5.44	9.89	40.0	10.47	19.6	0.0
2009	5	111.0	113.0	1,158.1	17.72	5.98	166.91	43.9	314.05	-437.1	0.0

Year	Month	Avg. of Stage (ft)	Avg. of Area (ac)	Ave of Volume (ac-ft)	Sum of Rain Lake (in)	Sum of Evaporation (in)	Rainfall (ac-ft)	Lake Evap. (ac-ft)	Runoff Vol (ac-ft)	S in-S out (ac-ft)	Del Vol (ac-ft)
2009	6	112.2	117.6	1,285.4	9.03	6.53	88.51	49.9	90.33	-1.6	127.3
2009	7	111.8	116.0	1,241.0	9.37	5.85	90.59	44.1	94.56	-185.4	-44.4
2009	8	111.7	115.7	1,231.2	7.66	5.80	73.86	43.6	108.63	-148.6	-9.8
2009	9	110.9	112.7	1,147.8	3.75	4.51	35.16	33.0	38.09	-123.6	-83.4
2009	10	110.9	112.7	1,147.8	2.25	3.76	21.16	27.5	20.81	-14.4	0.0
2009	11	110.3	110.3	1,082.8	0.81	2.62	7.41	18.8	8.78	-62.4	-65.0
2009	12	110.6	111.4	1,112.1	5.20	2.16	48.23	15.6	55.40	-58.7	29.3
2010	1	110.6	111.4	1,112.1	3.29	2.19	30.55	15.8	32.94	-47.6	0.0
2010	2	110.9	112.4	1,141.3	2.78	2.25	26.04	16.4	28.75	-9.1	29.3
2010	3	110.6	111.4	1,112.1	7.76	3.76	72.06	27.2	99.08	-173.1	-29.3
2010	4	110.9	112.6	1,145.7	4.22	5.17	39.59	37.9	43.61	-11.8	33.6
2010	5	110.7	111.7	1,121.8	1.51	6.03	14.07	43.8	15.81	-9.9	-23.8
2010	6	110.6	111.5	1,116.4	5.08	6.50	47.23	47.1	52.77	-58.3	-5.4
2010	7	110.8	112.2	1,135.9	6.53	6.02	61.07	43.9	67.00	-64.7	19.5
2010	8	110.4	110.5	1,088.2	10.47	5.42	96.46	38.9	127.63	-232.8	-47.7
2010	9	111.4	114.5	1,197.7	5.80	4.62	55.34	34.4	57.77	30.7	109.4
2010	10	109.8	108.2	1,024.3	0.00	4.03	0.00	28.3	0.00	-145.0	-173.3
2010	11	109.3	106.4	973.4	1.05	2.75	9.31	19.0	11.03	-52.2	-50.9
2010	12	109.0	105.2	938.7	0.62	2.06	5.40	14.1	5.88	-31.9	-34.7
2011	1	109.2	105.7	955.0	5.08	2.35	44.74	16.2	73.06	-85.4	16.3
2011	2	109.6	107.3	999.4	0.45	2.93	4.00	20.4	4.18	56.7	44.4
2011	3	109.3	106.3	971.2	7.19	4.58	63.73	31.6	131.93	-192.2	-28.2
2011	4	110.7	111.6	1,117.5	0.60	5.63	5.57	40.8	6.15	175.3	146.3
2011	5	110.0	109.2	1,051.4	1.96	6.76	17.84	48.0	20.31	-56.2	-66.1
2011	6	108.8	104.1	913.3	5.19	6.63	45.05	44.9	50.17	-188.5	-138.1
2011	7	108.3	102.2	865.4	6.00	6.38	51.14	42.4	53.39	-110.0	-47.8
2011	8	109.1	105.5	948.5	5.56	5.84	48.84	40.0	56.19	18.0	83.0
2011	9	109.2	105.7	955.0	2.40	4.62	21.11	31.7	25.75	-8.6	6.5
2011	10	109.5	106.9	988.6	6.17	3.59	55.01	25.0	70.43	-66.9	33.6
2011	11	109.5	106.9	988.6	0.29	2.81	2.62	19.5	3.26	13.7	0.0
2011	12	109.2	105.8	957.2	0.28	2.39	2.49	16.5	3.43	-20.9	-31.4
2012	1	109.0	105.1	936.7	0.27	2.66	2.34	18.2	2.71	-7.3	-20.5
2012	2	108.9	104.7	926.5	1.01	3.07	8.80	20.9	10.52	-8.6	-10.2
2012	3	108.7	103.7	903.1	1.89	4.43	16.37	29.9	19.18	-29.1	-23.4
2012	4	108.7	103.9	906.2	1.06	5.57	9.19	37.6	10.98	20.5	3.1
2012	5	107.9	100.6	824.7	5.11	6.25	42.80	40.9	46.14	-129.5	-81.4
2012	6	107.8	100.1	812.5	13.81	5.57	115.16	36.2	170.49	-261.6	-12.2
2012	7	110.1	109.4	1,055.7	5.06	6.26	46.14	44.5	50.21	191.4	243.2

Year	Month	Avg. of Stage (ft)	Avg. of Area (ac)	Ave of Volume (ac-ft)	Sum of Rain Lake (in)	Sum of Evaporation (in)	Rainfall (ac-ft)	Lake Evap. (ac-ft)	Runoff Vol (ac-ft)	S in-S out (ac-ft)	Del Vol (ac-ft)
2012	8	109.6	107.6	1,005.9	10.79	5.70	96.68	39.8	108.04	-214.7	-49.8
2012	9	110.1	109.2	1,052.5	4.69	4.63	42.71	32.9	45.28	-8.5	46.6
2012	10	110.1	109.2	1,052.5	4.87	3.59	44.31	25.5	49.50	-68.3	0.0
2012	11	110.1	109.2	1,052.5	0.39	2.58	3.57	18.3	3.76	11.0	0.0
2012	12	110.1	109.2	1,052.5	1.49	2.44	13.57	17.3	15.38	-11.6	0.0

Appendix D: Study for Estimating Groundwater Seepage and Nitrogen Loads from Septic Systems

The Ye and Zhu (2014) study is available on request. Please contact the following individual to obtain this information:

Woo-Jun Kang
Florida Department of Environmental Protection
Watershed Evaluation and TMDL Section
Water Quality Evaluation and TMDL Program
2600 Blair Stone Road, Mail Station 3555
Tallahassee, FL 32399-2400
Email: [Woo-Jun Kang](mailto:Woo-Jun.Kang@floridadep.gov)
Phone: (850) 245-8437

Appendix E: Important Links

Email addresses:

Woo-Jun Kang: woojun.kang@dep.state.fl.us

Mary Paulic: mary.paulic@dep.state.fl.us

Websites

ArcNLET:

<http://people.sc.fsu.edu/~mye/ArcNLET/>

Florida Department of Environmental Protection:

TMDL Program: <http://www.dep.state.fl.us/water/tmdl/index.htm>

Identification of Impaired Surface Waters Rule:

<http://www.dep.state.fl.us/legal/Rules/shared/62-303/62-303.pdf>

Florida STORET Program: <http://www.dep.state.fl.us/water/storet/index.htm>

2016 Integrated Report: <http://www.dep.state.fl.us/water/docs/2016-Integrated-Report.pdf>

Criteria for Surface Water Quality Classifications:

<http://www.dep.state.fl.us/legal/Rules/shared/62-302/62-302.pdf>

Basin Management Action Plans:

<http://www.dep.state.fl.us/water/watersheds/bmap.htm>

Florida Department of Health OSTDS Statistics:

<http://www.floridahealth.gov/environmental-health/onsite-sewage/ostds-statistics.html>

U.S. Census Bureau:

2010 Census Interactive Population Search, Florida:

<http://www.census.gov/2010census/popmap/ipmtext.php?fl=12>

Main website: <http://www.census.gov/>

U.S. Environmental Protection Agency:

Region 4: TMDLs in Florida:

<https://archive.epa.gov/pesticides/region4/water/tmdl/web/html/index-2.html>

National STORET Program:

<https://www.epa.gov/waterdata/storage-and-retrieval-and-water-quality-exchange>